



**Aladin Square  
User manual**



**deep down you want the best**

[scubapro.com](http://scubapro.com)

## SQUARE DIVING COMPUTER - DESIGNED BY DIVING ENGINEERS

Welcome to SCUBAPRO dive computers and thank you for purchasing Square. You are now the owner of an extraordinary partner for your dives. This manual provides you easy access to SCUBAPRO state of the art technology and Square's key features and functions. Should you wish to know more about SCUBAPRO diving equipment, please visit our website [www.scubapro.com](http://www.scubapro.com).



### WARNING

- Square has 120m/394ft operation depth.
- If 120m is exceeded, -- will be shown in the depth field and decompression algorithm does not calculate correctly.
- Diving with oxygen partial pressures higher than 1.6 bar (corresponding to a depth of 67m/220ft when breathing compressed air) is extremely dangerous and could lead to serious injury or death.



Square dive instrument is compliant with the European Union directive 2014/30/EU.

#### Standard EN 13319: 2000

Square dive instrument is also compliant with the European standard EN 13319: 2000 (EN 13319: 2000 – Depth gauges and combined depth and time measuring devices – Functional and safety requirements, tests methods).

# TABLE OF CONTENTS

<b>1. Introduction to Square .....</b>	<b>6</b>
1.0.1 Buttons .....	6
1.0.2 Display .....	7
1.0.3 Heart Rate Option .....	7
1.0.4 Battery .....	7
1.0.5 Square operation .....	8
1.0.6 Surface display .....	8
1.0.7 Surface interval counter .....	8
1.0.8 Checking the Altitude .....	9
1.0.9 Planning a dive .....	9
1.0.10 Reading the Logbook .....	10
1.0.11 SCUBA log's .....	11
1.0.12 Apnea log's .....	12
1.0.13 Gauge log's .....	12
1.0.14 Checking the battery status .....	13
1.0.15 Settings .....	13
1.0.16 Settings Lock .....	14
1.0.17 Time set menu .....	15
1.0.18 Setting the alarm clock .....	15
1.0.19 Setting the UTC .....	16
1.0.20 Setting the time .....	16
1.0.21 Set the AM/PM or 24h mode .....	16
1.0.22 Setting the date .....	16
1.0.23 Setting the sound mode (silent modes) .....	17
1.0.24 Setting the user preferred units .....	17
1.0.25 Setting the Backlight on duration .....	17
1.0.26 Deactivating the water contacts .....	18
1.0.27 Checking the device ID .....	18
1.1 Settings at the dive mode .....	19
1.2 Gas settings .....	19
1.2.1 Set Gas 1 .....	20
1.2.2 Set Gas D .....	20
1.2.3 Nitrox reset time .....	21
1.2.4 Desaturation reset .....	21
1.3 SCUBA settings .....	22
1.3.1 Maximum dive depth alarm .....	22
1.3.2 Maximum dive time alarm .....	22
1.3.3 Setting the Micro Bubble level .....	22
1.3.4 Setting the Safety stop timer .....	23
1.3.5 Set HR limits (Workload settings) .....	23
1.3.6 Set the PDI Stop .....	23
1.3.7 Selecting the salt (ocean) or fresh water .....	24
1.4 Apnea Settings .....	25
1.4.1 Setting the dual depth alarm .....	25
1.4.2 Setting the depth incremental alarm .....	25
1.4.3 Setting the dive time interval alarm .....	26
1.4.4 Setting the surface interval alarm .....	26
1.4.5 Setting the low Heart Rate limit alarm .....	26
1.4.6 Setting the Ascent speed alarm .....	26
1.4.7 Setting the water density .....	27

1.5	Set Up/Down Time Counter for the dive .....	27
1.6	Algorithm selection .....	27
1.7	HR enable .....	28
<b>2.</b>	<b>Square as a dive computer .....</b>	<b>28</b>
2.1	Diving with Square .....	28
2.2	Altitude diving .....	29
2.2.1	Altitude classes, altitude warning and no-fly time after a dive. .	29
2.2.2	Altitude and the decompression algorithm .....	30
2.2.3	Prohibited altitude .....	30
2.2.4	Decompression dives in mountain lakes .....	31
2.3	No-dive warning after a dive .....	31
2.4.1	Desaturation reset .....	31
2.5	Diving with nitrox or with another decompression gas .....	32
2.5.1	Diving with more than one gas mix .....	33
2.5.1.1	Switching gas mixture during the dive .....	33
2.5.1.2	Switching back to a gas mixture with lower oxygen concentration .....	34
2.5.1.3	Gas switch not carried out at the planned depth .....	34
2.5.1.4	Delayed gas switch .....	34
2.5.1.5	Manual gas switch at a depth deeper than its MOD ...	34
2.5.1.6	Submerging below the MOD after a gas switch .....	34
2.6	Warnings and alarms .....	34
2.6.1	CNS O <sub>2</sub> = 75% .....	35
2.6.2	No-Stop time = 2 minutes .....	35
2.6.3	Entering decompression .....	35
2.6.4	Entering level stops .....	35
2.6.5	L0 no stop time = 2 minutes when diving an MB level .....	36
2.6.6	Entering deco when diving an MB level .....	36
2.6.7	Ascent rate .....	36
2.6.8	MOD/ppO <sub>2</sub> .....	37
2.6.9	CNS O <sub>2</sub> = 100% .....	37
2.6.10	Missed decompression stop .....	38
2.6.11	Low battery .....	38
2.7	Display information .....	38
2.7.1	Display configuration during the dive .....	39
2.7.2	Setting bookmarks .....	39
2.7.3	Safety stop timer .....	40
2.7.4	Activating the backlight .....	40
2.7.5	Diving with MB levels .....	40
2.7.6	Display information .....	40
2.7.7	Display of underlying L0 decompression information .....	41
2.7.8	Cascading MB levels .....	41
2.7.9	Level stop ignored/MB level reduced .....	41
2.7.10	PDI Stops .....	41
2.8	Gauge mode .....	42
2.9	Apnea mode .....	43
<b>3.</b>	<b>Square accessories .....</b>	<b>44</b>
3.1	HR belt .....	44

<b>4. Square PC interface .....</b>	<b>45</b>
4.1 Shark .....	45
4.2 Introduction to SCUBAPRO LogTRAK .....	45
4.2.1 Download dive profiles .....	45
4.2.2 Change warnings/settings of the Square and reading computer info .....	46
<b>5. Taking care of Square .....</b>	<b>47</b>
5.1 Technical information .....	47
5.2 Maintenance .....	47
5.3 Replacing the battery in Square .....	47
5.4 Warranty .....	48
<b>6. Glossary .....</b>	<b>49</b>
<b>7. Index .....</b>	<b>51</b>

# 1. INTRODUCTION TO SQUARE

Your Square User Manual is divided into five main chapters.

**1 Introduction to Square.** This chapter provides an overview of the Square computer and describes its operating modes and functions when on the surface.

**2 Square as a dive computer.** This chapter describes all settings and functions of Square as a dive computer and takes you underwater with Square. It's about everything Square can and will do to enhance your safety and fun underwater.

**3 Square accessories.** This chapter describes briefly the Square extras that you can purchase to get maximum out of your dive computer in all conditions.

**4 Square PC interface.** This chapter is about personalization and customization. It describes how to change settings, to download and manage your logbook.

Square is a technologically-advanced instrument that can accompany you during your underwater adventures while providing you with accurate depth, time and decompression information.



The buttons allow operating functions, access menus and changing settings while on the surface. During the dive they set bookmarks; show further information on the computer screen, change the gas and activate the backlight.

Square has been designed for easy use from the first day on for the beginner with standard factory settings but the selections and features allow the advanced user to customize according to their specific needs. So, it is recommended to study and understand this manual before diving with your Square.

It is time to dive into the details now. We hope you will enjoy getting to know your new computer and we wish you many happy dives with Square.

## 1.0.1 Buttons

Square has one navigation button. It can be pressed from left or right side. The shape has been selected so that even with thick neoprene gloves you can follow the button from left to right with your finger without loosing the touch of the button.

Both left and right ends of the navigation button have different functions when pressed short or pressed and hold (long press). Generally the buttons operate as follows:

Left short = scroll left at the menu "left", "L"

Left long = escape "ESC"

Right short = scroll right at the menu "right", "R"

Right long = select or confirm the setting "SEL"

### 1.0.2 Display

The display information has been divided in a pattern of a dive profile.



Various situations like ascent, descent, stops can be easily located from the profile.

### 1.0.3 Heart Rate Option

Square firmware may be delivered without the heart rate option. In this case please ignore the user manual descriptions referring to heart rate functions.

### 1.0.4 Battery

Square uses a battery of the type CR2450 which is available from your SCUBAPRO dealer. Square will shortly test the battery status after each activation (switch on) and indicate only the state if the battery is too low. In addition, you can verify the status of the battery by providing the check at the main menu: Checking the battery status.

**NOTE:** A battery level indication LO means that battery has some reserve left but battery change is recommended before a dive. Also, with LO level battery the backlight and alarm tones are not activated.

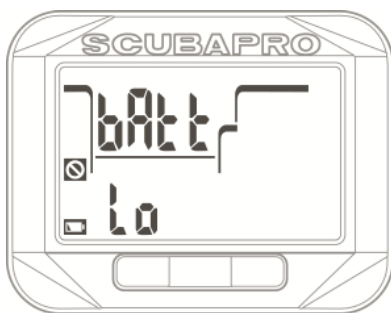

## ⚠ WARNING

Starting a dive when the battery LO is indicated can cause the computer to fail during the dive! Replace the battery before any diving activity if the battery LO appears. When the 'do not dive symbol' appears with the text change battery Square can not be used for diving before a fresh battery is replaced.

Please refer to chapter **Checking the battery status** for details how to check your Square battery status.

## ⚠ WARNING

Replacing the battery requires opening the electronic compartment of Square. You must take extreme care when performing the battery change operation in order to ensure the water tightness of the dive computer. Failing to do so will cause the dive computer to flood during your next dive and permanently ruin it. Damage to Square due to an improper battery replacement is not covered by warranty. We strongly recommend having the battery change operation be carried out by your SCUBAPRO appointed dealer.

See chapter **Replacing the battery in Square** for information on how to replace the battery.

### 1.0.5 Square operation

The diagram below shows the main menu logic in a chart form. The diving functions are described detailed at chapter **Square as a dive computer**.

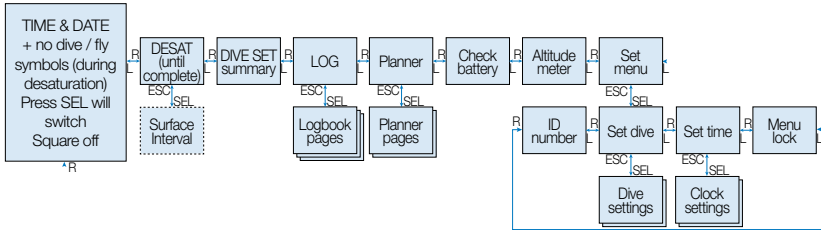

The reference point for any description of Square is the main time of day display. This is the display that appears after waking the Square up from sleep mode by pressing the right button and in which the current time and date are shown.

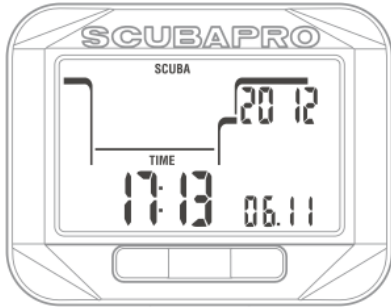

By simply pressing buttons right or left from the **time of day** display you can scroll through the various menus in SQUARE. The chart above shows the sequence of the menus. Note that when you first reach a menu, you are “outside” of it. You must press SEL to enter the actual menu.

**NOTE:** When Square has wet contacts activated and they detect moisture in between, the Square goes automatic to **Surface display**.

### 1.0.6 Surface display

When you have not been diving with your Square for a while (no desaturation left) the surface mode may appear as shown below, indicating settings like the operation mode (scuba, gauge, apnea), water type, heart rate, MB level and gas mix:

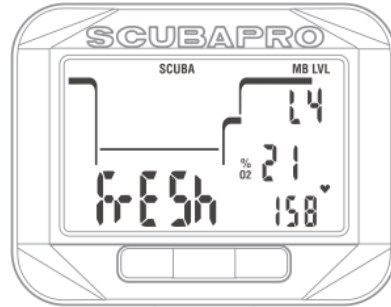

After a dive the display may appear as shown below, indicating maximum allowed elevation where diver may ascent, desaturation time and no repetitive dive symbol (too short interval):

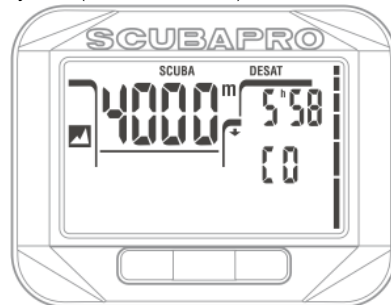

### 1.0.7 Surface interval counter

After a dive you can check your surface interval by pressing SEL at the surface display. The text Int and a time appears to the display. The surface interval counter counts until desaturation is complete, after that this display cannot be selected.



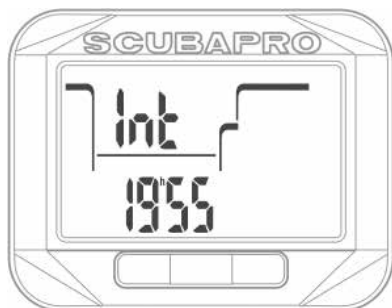

### 1.0.8 Checking the Altitude

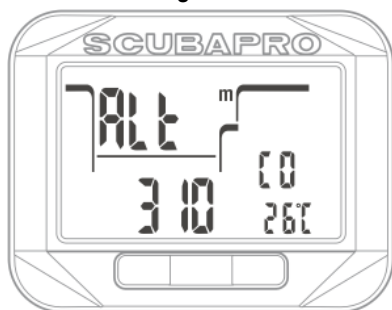

At the altitude menu the current altitude is calculated from the **barometric pressure** and shown at the bottom row left. The current altitude class is shown at middle row right and this is used as ambient pressure for diving algorithm calculations. At the bottom row right the current temperature is shown.

**NOTE:** barometric pressure is a variable changing with weather and atmospheric pressure at that elevation. Dive algorithm uses Altitude Classes which are directly derived from the barometric pressure. Altitude is counted from the current barometric pressure and it is therefore a relative value.

The altitude can be adjusted when current elevation is known by pressing the SEL. The altitude value will start blinking. By pressing right or left the value can be adjusted in 10m/50feet steps. By pressing SEL you can confirm the altitude value. Adjusting the altitude elevation has no effect on altitude class. More about diving in altitudes is explained in chapter **Altitude diving**.

**NOTE:** Different combinations m&°C, Ft&°C, m&F or Ft&F can be selected from the dive mode menu: Units.

### 1.0.9 Planning a dive

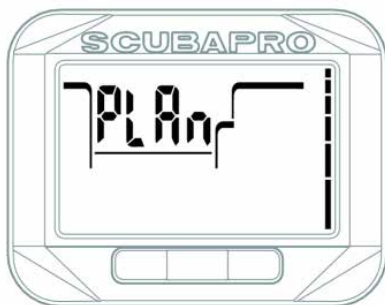
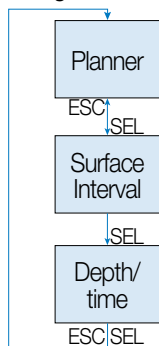

You can plan your next dive based on your body's nitrogen saturation. The planner is also using following information:

1. Selected oxygen concentration and active tanks
2. Selected water type
3. Selected MB level
4. Water temperature of the most recent dive
5. Altitude range
6. Status of tissue saturation at the time the planner is started
7. A normal workload of the diver and observance of the prescribed ascent rates.

By pressing SEL at the planner menu you will get into the planner directly or to the surface interval setting (repetitive dive).

**NOTE:** When Square is in Gauge or Apnea modes the Planner is disabled and Planner OFF is shown in this menu.



In case you have done a dive and you plan to make another dive during the desaturation phase, you must start a plan by giving the time you would still stay at the surface.

By pressing the right or left you can step the time in 15 minutes steps.

In case Square is displaying the no-dive warning, the duration of the warning itself is displayed as recommended surface interval for planning purposes (rounded up to the nearest fifteen-minute increment).

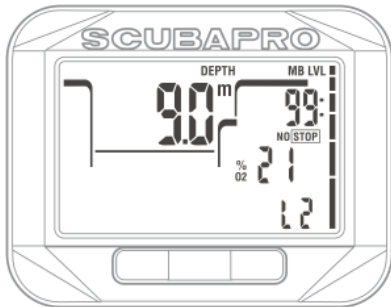

When surface interval is given or if you have no remaining desaturation left, the planner depth value starts blinking. By pressing right or left you can set the depth in 3m/10feet steps.

The no decompression dive time is shown for that depth at the top row right.

Minimum depth for planning is 9m/30feet. The planner allows only depths according to maximum  $ppO_2$  given to the GAS1. If GAS1 MOD is shallower than 9m/30feet, planning is not allowed and information LO  $ppO_2$  is shown.

The gas oxygen content and maximum  $ppO_2$  settings are given at the dive mode menu: SET GAS.

## ⚠ WARNING

If you have set  $ppO_2$  max to OFF, the planner will allow depths up to maximum of 120m/394ft. Air/nitrox dives with high  $ppO_2$  are extremely dangerous and can lead to death. Be aware that exposures to high  $ppO_2$  will lead CNS clock value to exceed maximum recommended 100%.

👉 NOTE: The dive planner considers all programmed gas mixtures to be used at the planned dive when computing no-stop times or decompression schedules.

By pressing SEL for planned depth the dive time appears at bottom row. Start point (minimum now) is the no decompression time. By pressing right or left you may change the time in 1 minute steps. When no decompression time is exceeded the planner gives the deepest decompression depth and time on top of the black DECO STOP symbol. MB level stops (if selected) are shown at the same place just with symbol STOP. Total Ascent Time (TAT) is shown at the middle right. Total Ascend Time (TAT) is shown at the middle right. If the plan reaches CNS clock limit of 75% the symbols CNS  $O_2\%$  starts blinking and replaces the TAT value at middle right.

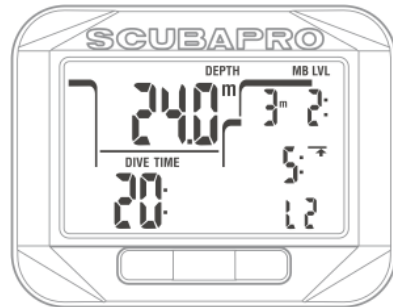

By pressing SEL or ESC the planner will exit and you will get to the main menu.

### 1.0.10 Reading the Logbook

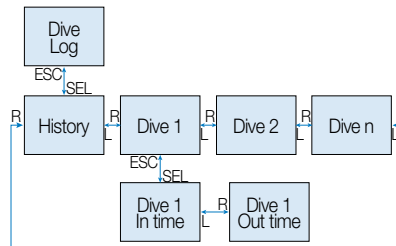



You can check the main information about your dives from the logbook by pressing SEL at the log menu.

The first page shown is the dive history.

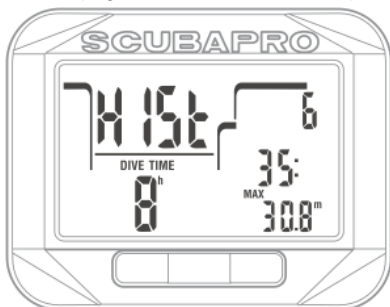

The computer with display shown above has logged the deepest dive of 30.8 meters and longest dive time of 35 minutes. In total 8 hours of diving and 6 dives has been done with this Square. History cannot be erased. By pressing right or left you can scroll the dives in the memory.

### 1.0.11 SCUBA log's

In SCUBA mode there is a main page showing depth, dive time, log number, Gas 1 content, temperature and possibly symbols like no repetition dive.

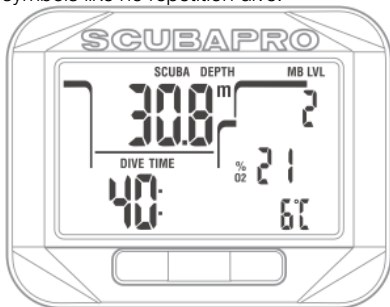

By pressing SEL you will select the dive and get to the sub display which shows in SCUBA mode the dive start time and date.

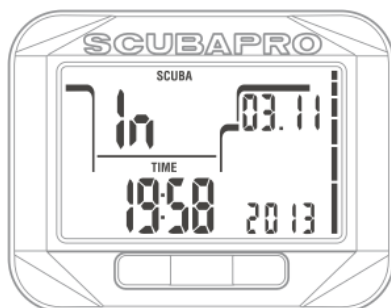

By pressing right you will get to next sub display that shows surfacing time and average depth.

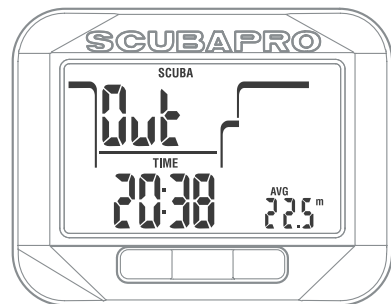

By pressing right you will get to next sub display that shows heart rate data:

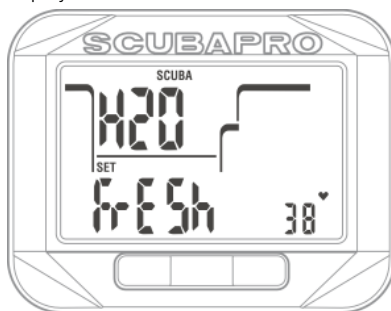

### 1.0.12 Apnea log's

In Apnea mode the main page shows max dive session depth, total dive session time, log number, amount of dives at the session and max dive time at the session:

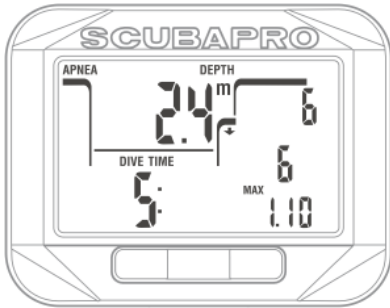

By pressing SEL you will select the dive and get to the sub display which shows in Apnea mode the dive start time and date:

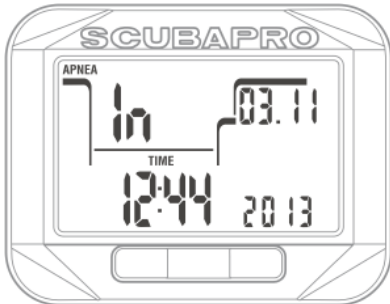

By pressing right you will get to next sub display that shows surfacing time, maximum ascent rate of the session and the deepest water temperature:

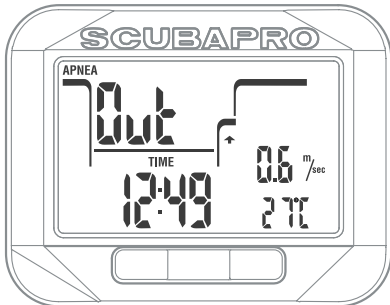

By pressing right you will get to next sub display that shows the water density and lowest heart rate of the session:

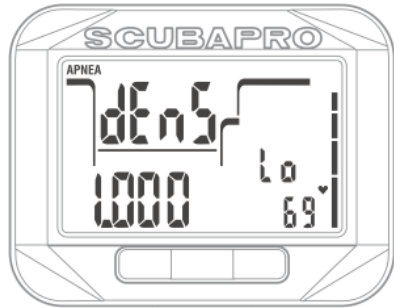

### 1.0.13 Gauge log's

In Gauge mode the main page shows depth, dive time, log number and temperature:

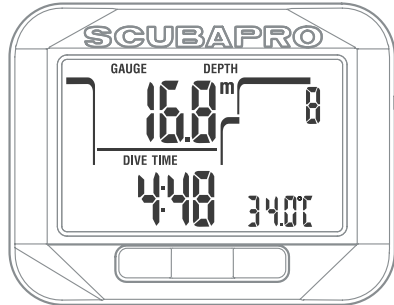

By pressing SEL you will select the dive and get to the sub display which shows in Gauge mode the dive start time and date.

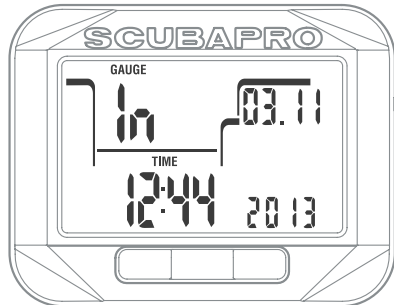

By pressing right you will get to next sub display that shows surfacing time and average depth:

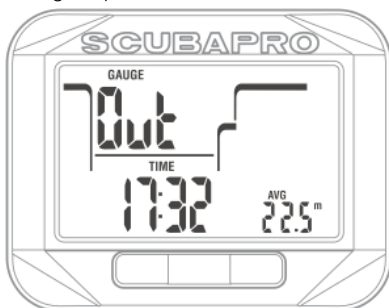

#### 1.0.14 Checking the battery status



The battery status menu shows how much energy is left in the CR2450 battery. A fresh battery shows high.

Square is periodically measuring the battery status and you can manually trigger a measurement by pressing SEL in battery status menu.

The intelligent battery algorithm will limit some functions towards the end of the lifetime. See the table below for the status and functions.

Indicator in battery status display	Battery status	Function limitations
High	Fresh battery	none
Medium	Battery ok for diving	none
Low	Weak battery, change to fresh	Acoustic alarms and Backlight not operating, <b>diving not recommended</b>

 **NOTE:** The battery capacity and voltage at the end of the lifetime may vary between battery manufacturers. Generally operation at low temperatures decreases the battery capacity. Therefore, when the battery indicator drops to Low, change the battery to a fresh one before next dive.

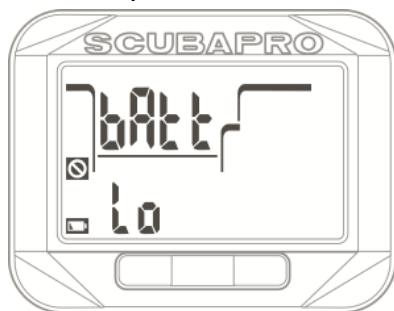

#### 1.0.15 Settings

By pressing SEL at the Set menu (and if settings lock is deactivated) you come to time set selection.

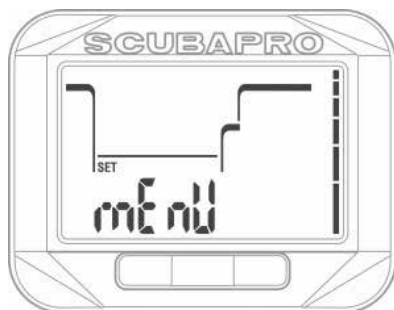

If the setting lock is activated Square will request the lock pin number before the settings can be edited.

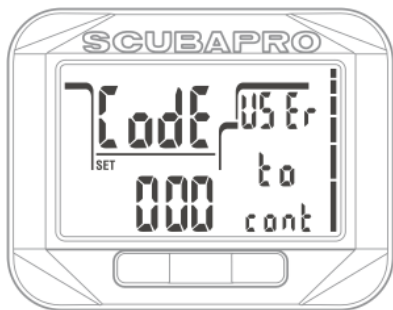
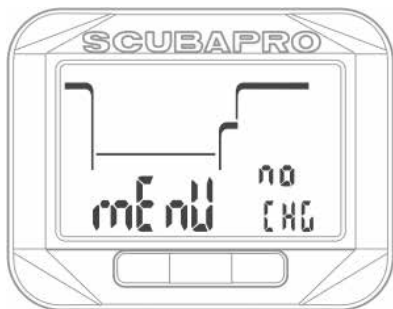

### 1.0.16 Settings Lock

Square is delivered with factory settings for easy start on normal air diving. As a default the setting lock is deactivated. If you wish to lock the settings for example to prevent the value changes for rental use then the lock can be activated at settings main menu by selecting Code on and giving a personal 3 digit pin number.

By pressing left after selecting the set menu the code off is shown. By pressing SEL the state on or off starts blinking and you may change this by pressing right or left.

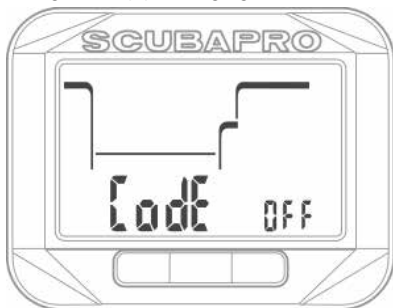

By pressing SEL you will confirm the setting. If you enabled the code the next page will appear blinking the first digit. By pressing right or left you may select any number between 0 and 9. By pressing SEL the first digit is set and next digit starts blinking. After the 3rd digit is confirmed by pressing the SEL the code will be set.

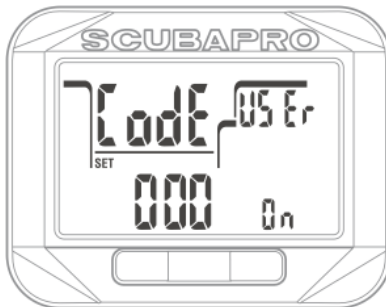

**NOTE:** At battery change the lock pin number will be reset and lock will be deactivated.

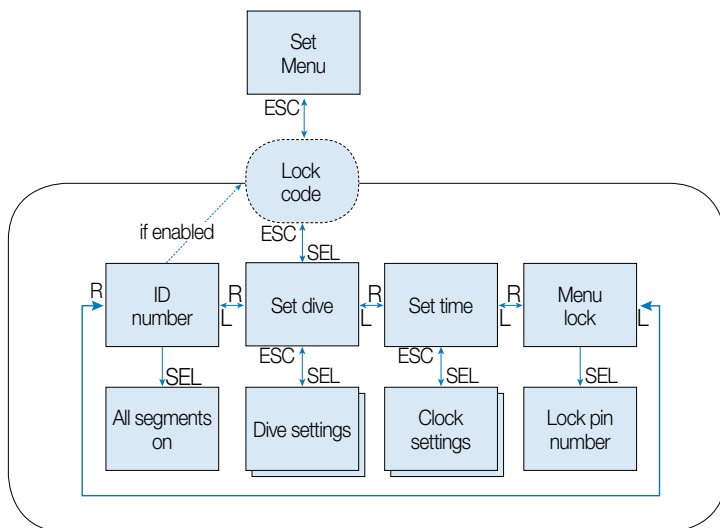

Settings are divided into two main categories namely clock settings and dive settings.

### 1.0.17 Time set menu

By pressing SEL at the set time menu the following selections can be scrolled by pressing right or left button.

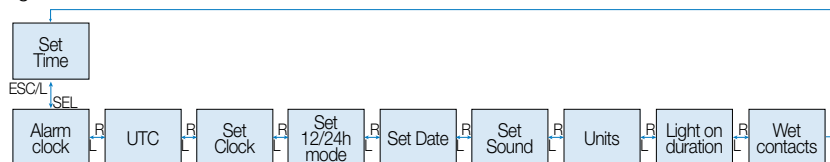

### 1.0.18 Setting the alarm clock

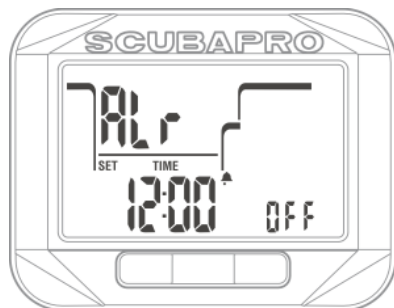

By pressing the SEL at alarm menu the hours of the alarm will start blinking. You can scroll the hours setting by pressing right or left.

By pressing SEL the minutes will start blinking and by pressing right or left you can scroll them.

By pressing SEL the state of alarm will start blinking and can be selected either on or off by pressing right or left.

Pressing SEL button will confirm the settings.

**NOTE:** Sound off setting does not affect the alarm clock. However, intelligent battery stretching algorithm disables all warning tones when the battery indication is showing "LO".

### 1.0.19 Setting the UTC

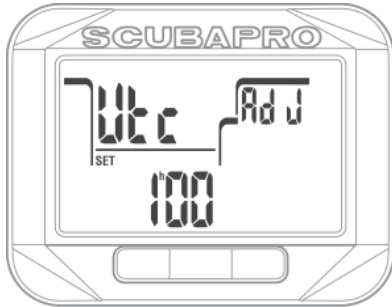

UTC setting will change the shown time compared to Greenwich 0-Meridian. This feature is practical when traveling through different time zones.

By pressing SEL at UTC menu, the hours will start blinking. You may edit them in range of -13..+14 hours by pressing right or left. By pressing SEL the minutes will start blinking and you may edit them in 15 minutes steps by pressing right or left. By pressing SEL will save the UTC setting.

### 1.0.20 Setting the time



In set time menu the current time is shown on the menu. By pressing SEL the time setting will be activated and hours start blinking. You may change the hours by pressing right or left. By pressing the SEL the minutes start blinking and you may now edit them by pressing right or left. By pressing SEL the new time will be set.

**NOTE:** seconds cannot be edited; they always start counting from 0 when minutes are confirmed by pressing SEL.

### 1.0.21 Set the AM/PM or 24h mode

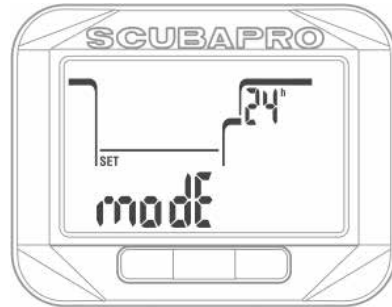

By pressing SEL at the time mode menu the numbers 24h or alternatively AM/PM start blinking. By pressing right or left you may change between the modes. By pressing SEL the mode will be confirmed.

**NOTE:** the AM/PM selection will change the day format to following: Month.Date.Year. This change takes place in main time & date display and in dive computer log book.

### 1.0.22 Setting the date



By pressing SEL at the date menu the first two digits of the day/month field start blinking and they can be changed by pressing right or left (in 24h mode the first digit is days, in 12h mode the month is first). Pressing SEL will confirm the setting and next two digits start blinking. Again, by pressing SEL these are confirmed and the year will start blinking. By pressing right or left the year can be edited. By pressing SEL the year will be confirmed.



### 1.0.23 Setting the sound mode (silent modes)

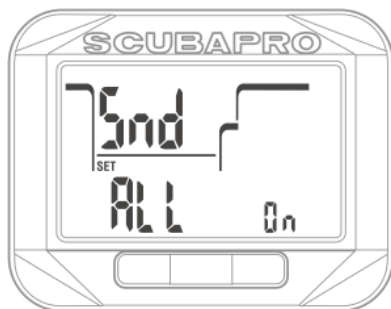

By pressing the SEL at the sound menu one of the following options start blinking and they can be scrolled by pressing right or left:

- All on = All audible functions are enabled
- Warn on = Warnings, Alarms are enabled
- Air on = Alarms are enabled
- All off = All audible functions are disabled

By pressing SEL you will confirm the setting. In case you want to activate All off mode (silent mode), the Square will request the safety pin code.

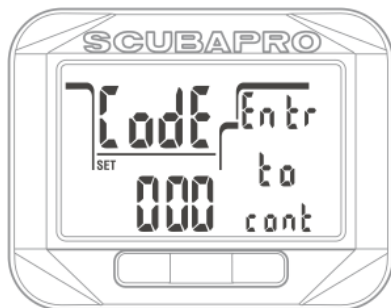

The text code (enter to continue) will appear and the first digit of the code will start blinking. By pressing right or left buttons the number can be edited and by pressing SEL button the number is confirmed and next number starts blinking. The unlock code for sound off is: 313.

**NOTE:** the all off selection will disable all audible dive mode alarms and warnings. This is potentially dangerous.

**NOTE:** the only exception to the silent operation is the alarm clock, it will alarm when activated even if main setting is: All off.

### 1.0.24 Setting the user preferred units

The user may select between depth and temperature unit combinations. The effect takes place in dive mode, in the log book, alarm settings, altitude settings etc.

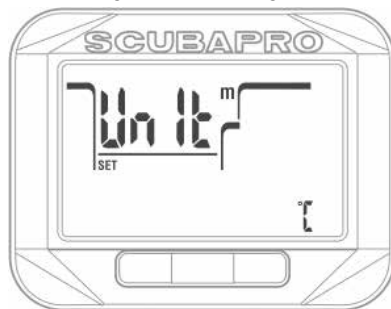

By pressing SEL in this menu the depth unit selection starts blinking. By pressing right or left buttons the value can be changed between meter and feet. By pressing SEL the temperature field starts blinking. Again, by pressing right or left the value may be changed between °C or °F. By pressing SEL button both unit settings will be confirmed.

### 1.0.25 Setting the Backlight on duration

By pressing SEL on this menu the backlight duration at middle row right starts blinking. By pressing right or left you may scroll between values:

- time 4,6,8,10,15,20,25,30,40,50,60 seconds
- "--" OFF backlight deactivated

The selected value will be confirmed by pressing SEL.

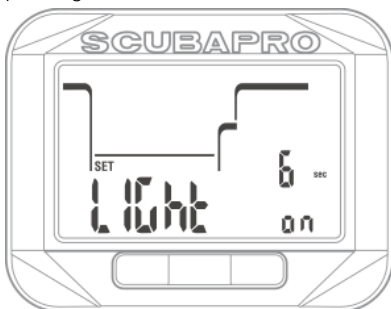

### 1.0.26 Deactivating the water contacts

By pressing SEL on this menu the selection on or off at the bottom row starts blinking. By pressing right or left you may select between active or inactive water contacts. You may confirm the selection by pressing SEL again.

**NOTE:** by selecting water contacts off you may delay your dive start time up to 1 minute. However, with inactive water contact you prevent you Square from switching to dive ready mode when moisture for example at your gear bag would accidentally activate the water contacts.



### 1.0.27 Checking the device ID



**Every Square has an individual ID number. 10 digits are shown in this menu. This number is used for secure coding your log book and other communication with PC/MAC.**

By pressing SEL in this screen the Square will show all the display segments for 3 seconds and returns showing ID after that.

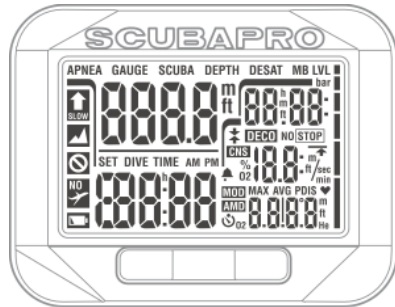

## 1.1 Settings at the dive mode

The dive computer functions of Square on the surface include, among others, setting the oxygen concentration for nitrox diving, setting the MB level of the decompression algorithm, setting various warnings and personal preferences.

By pressing SEL at the Settings menu (and if settings lock is deactivated) you can scroll to DIVE settings by pressing right or left and confirm the selection by pressing SEL.

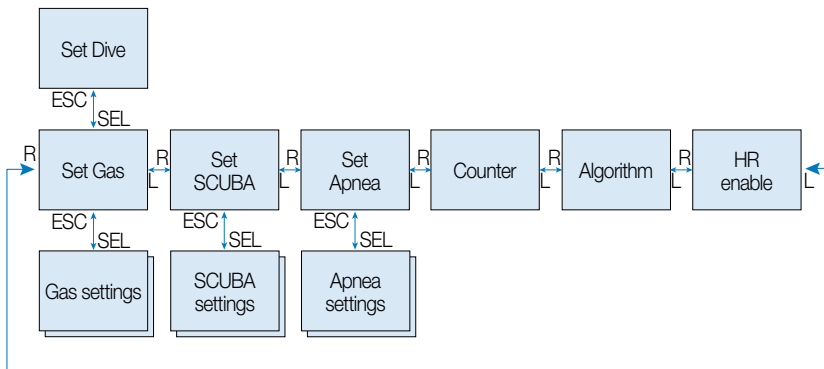

## 1.2 Gas settings

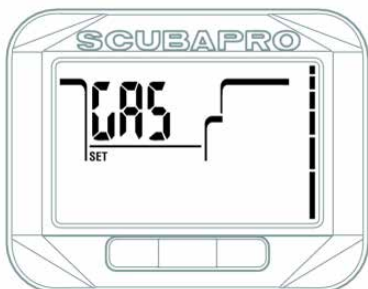

By pressing right or left at the dive settings you can scroll to Set Gas menu. By pressing SEL at this display will bring you to sub menu that allows changes to used Gas options in SCUBA mode.

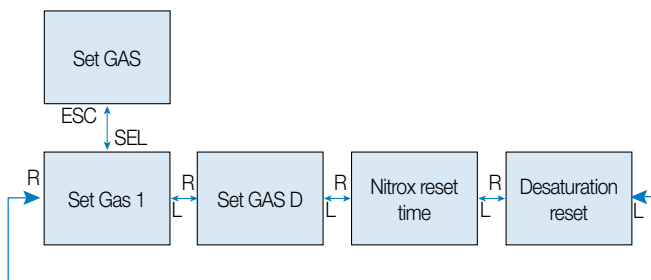

### 1.2.1 Set Gas 1

You may use your Square with the all nitrox mixes from Air to pure oxygen.

By pressing the SEL in this display the oxygen content of the Gas 1 starts blinking. By pressing right or left you may scroll the value from 21 up to 100%.

By pressing SEL the ppO<sub>2</sub> starts blinking. By pressing right or left you may select the value from 1.00 bar up to 1.60 bar. The Maximum Operation Depth (MOD) for the gas and selected ppO<sub>2</sub> is shown at the bottom right.

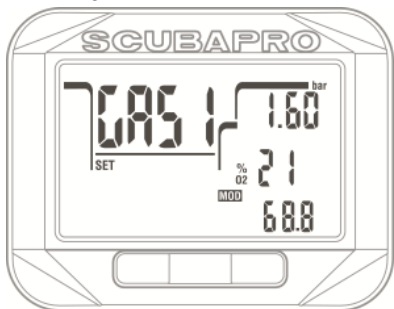

It is possible to disable the MOD setting (- - shown at the field), but this requires the security code 313 from the user. By pressing the SEL button the user will accept the given value.

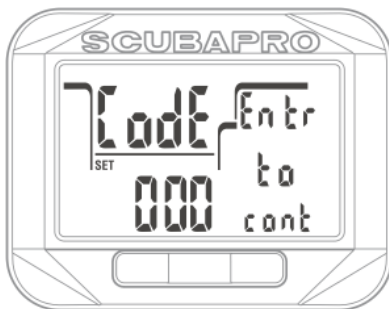
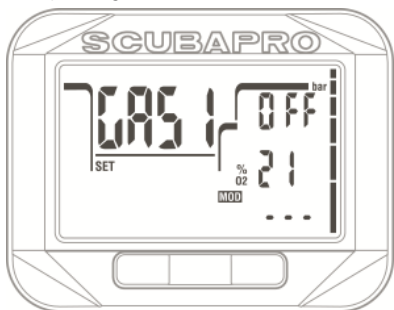

☞ NOTE: Diving with a ppO<sub>2</sub> higher than 1.4 is dangerous and may lead to unconsciousness, drowning and death.

☞ NOTE: ppO<sub>2</sub> is fixed to 1.60 bar when selected oxygen content is 80% or higher.

### 1.2.2 Set Gas D

When you are planning to make an extended no stop dive or decompression dive with another mix for accelerated decompression you may enable the Gas D. As a default the value the Gas D is disabled and the content field is blank.

You may select the Gas D content and ppO<sub>2</sub> combination so that the MOD is 3m/10ft shallower than with Gas 1.

By pressing SEL at this display the oxygen content starts blinking. By pressing right or left buttons you may scroll the value. By pressing the SEL the ppO<sub>2</sub> value starts to blink. By pressing right or left the value may be selected from 1.00 bar up to 1.60 bar in 0.05 bar steps. By pressing SEL the Gas D setting is confirmed and will be used at the next dive or planner use.

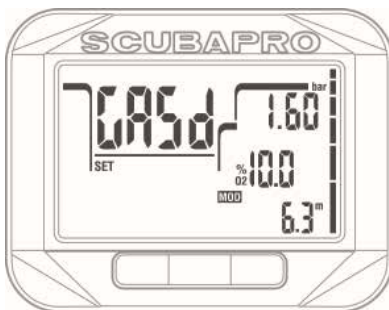

☞ **NOTE:** Gas d is disabled when -- is shown at %O<sub>2</sub> contents field.

☞ **NOTE:** To learn more about multi gas diving, read the chapter: Diving with more than one gas mix.

### 1.2.3 Nitrox reset time

If you are generally diving with one gas or air only and want to return to this setting after occasional nitrox or multi gas dive, you can preset a default time when your Square will reset to air and disable the Gas D. By pressing SEL in this menu the nitrox reset time starts blinking. By pressing right or left you may scroll the reset time from 1 hour up to 48 hours or disable the nitrox reset time option by selecting --. By pressing SEL the nitrox reset time will be confirmed.

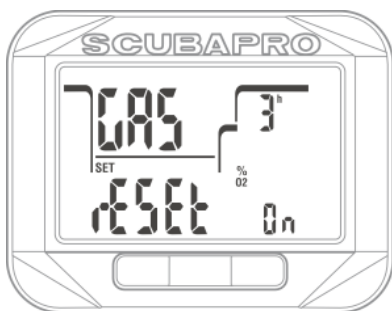

### 1.2.4 Desaturation reset

#### ⚠ WARNING

**Resetting desaturation will effect calculations of the algorithm and this may lead to serious injury or death. Do not reset desaturation without a solid purpose.**

When Square is still counting down the desaturation, some menu changes are not possible. In case the user decides to reset the desaturation, the safety code 313 must be given. This procedure secures unwanted resetting and the desaturation reset will be stored to a memory. At the next dive log the desaturation symbol will be shown.

By pressing SEL at this menu the enabling field text starts blinking. By pressing right or left you may select between on or off. By selecting off the safety code input screen

will appear. By pressing right or left the numbers can be edited. By pressing SEL the digit is confirmed and the next digit can be edited. After 3rd number, when correctly given the desaturation reset becomes effective and desat time is reset to 0.

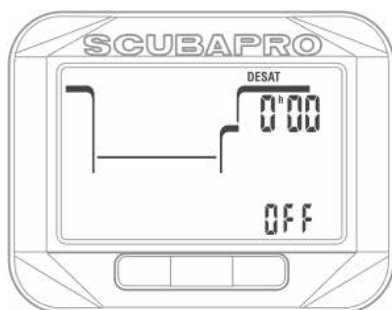
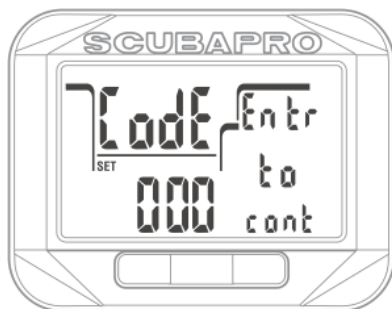
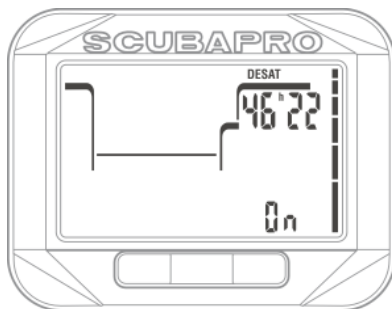

### 1.3 SCUBA settings

A set of SCUBA related selections are grouped to this menu.

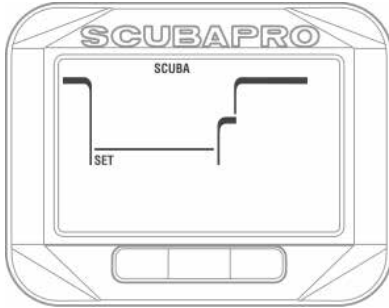
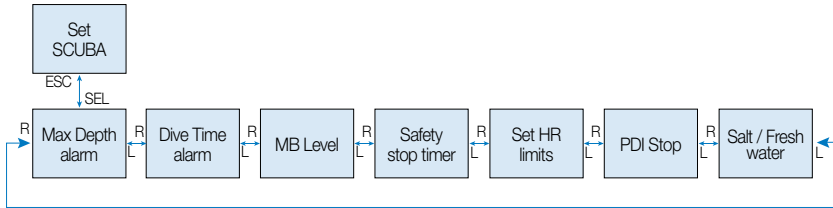

By pressing the SEL button the following menu's can be scrolled down by pressing right or left.

#### 1.3.1 Maximum dive depth alarm

By pressing SEL in this menu the depth value starts blinking. By pressing right or left the value can be selected from 5 up to 100 meters (20..330 feet) in 1m/5ft steps. By pressing SEL the function starts blinking and you may select between on or off by pressing right or left buttons. The selection is confirmed by pressing SEL button.



#### 1.3.2 Maximum dive time alarm

By pressing SEL in this menu the time value starts to blink. By pressing right or left the value can be selected from 5 up to 195 minutes in 5 minute steps. By pressing SEL button the function starts blinking and you may select between on or off by pressing right or left buttons. The selection is confirmed by pressing SEL button.

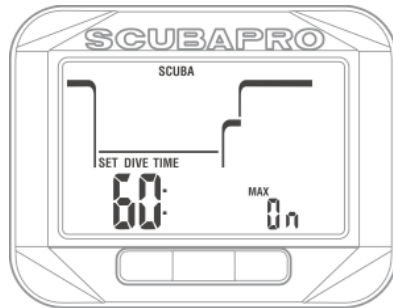

#### 1.3.3 Setting the Micro Bubble level

By pressing SEL in this menu the Micro Bubble level starts to blink. By pressing right or left you may select personal setting from L0 up to L5. L5 is the most conservative setting. The selection is confirmed by pressing SEL button.

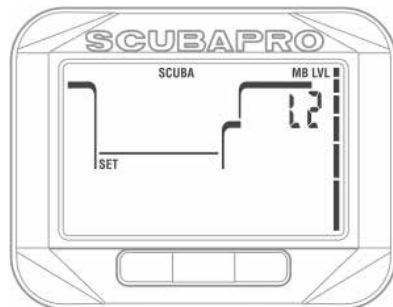

☞ *NOTE: more about diving with the MB levels, read chapter: Diving with MB levels.*

### 1.3.4 Setting the Safety stop timer

By pressing SEL at this menu the function at bottom row will start blinking and by pressing right or left following options may be selected:  
 Off = safety stop timer is not activated  
 Push = safety stop timer will start at the end of the dive with button press  
 Auto = safety stop timer will start automatic when the depth at the end of the dive becomes less than 5m/15ft and all decompression or MB stops have been accomplished.

By pressing SEL the function is confirmed and the time starts blinking. By pressing right or left you the value may be selected from 1 to 5 minutes. By pressing SEL the time is confirmed.

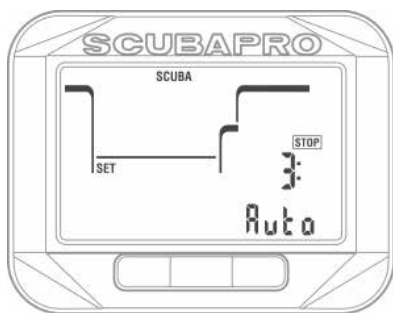

### 1.3.5 Set HR limits (Workload settings)

By pressing SEL in this menu the HR high value starts blinking. By pressing right or left the value can be changed from 140 up to 220. This is your maximum heartbeat setting, when you are for example diving against the current. By pressing SEL the low value starts blinking. By pressing right or left the value can be changed from 60 up to 120. This is your heartbeat when you are relaxed in the water and for example holding from the anchor line. By pressing SEL again the limits are confirmed.

☞ *NOTE: Diving experience and sport exercises have an effect to your heart rate limits during diving. You may need to edit the limits after you have used your Square*

*for some time. If you want to learn more about the heart rate related to diving, you may read a SCUBAPRO booklet 2012: Dr. Uwe Hoffmann, Dr. Tobias Dräger, "Sicherer Und Besser Tauchen Mit Herzfrequenzmessung."*

☞ *NOTE: Refer to chapter **HR enable** to learn how HR function can be enabled.*

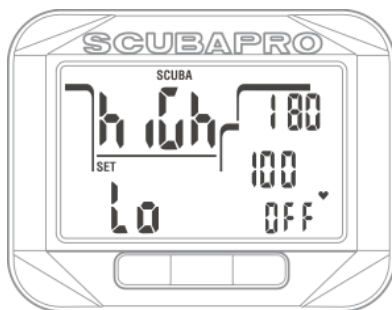

### 1.3.6 Set the PDI Stop

By pressing SEL the PDIS function starts blinking. By pressing right or left the value can be set to on or off. By pressing SEL the setting is confirmed.

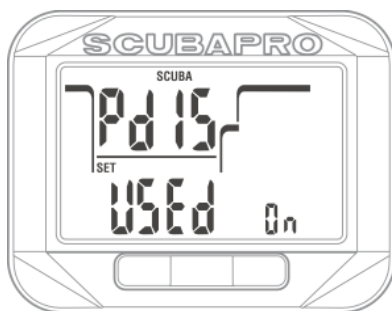

☞ *NOTE: To learn more about diving with PDI stop, read the chapter **PDI Stops**.*

### 1.3.7 **Selecting the salt (ocean) or fresh water**

Square measures a pressure and converts as depth from it by using the water density as a constant. 10m/33ft depth at salt water corresponds approximately to 10.3m/34ft at fresh water.

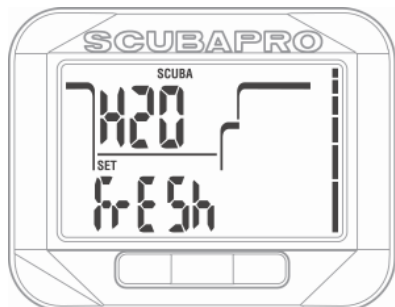

By pressing SEL at this menu the Salt or Fresh at the bottom row starts blinking. You may scroll between these two settings by pressing right or left and confirm the selection by pressing SEL.



## 1.4 Apnea Settings

Apnea diving related selections are grouped in this menu.

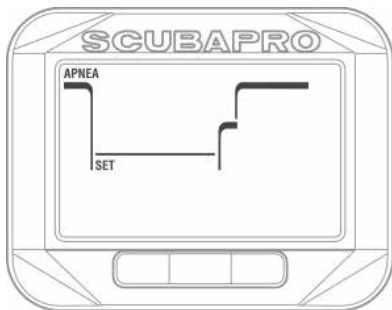
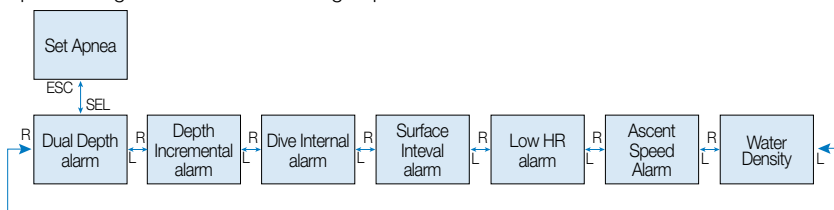

By pressing the SEL button the following menu's can be accessed.

### 1.4.1 Setting the dual depth alarm

By pressing the SEL at this menu the first depth starts blinking. By pressing right/left buttons you may select the first depth alarm from 5 to 100 meters (20..330 feet). By pressing SEL the first value is confirmed and the second alarm starts blinking. Like the first, by pressing right or left buttons the second alarm may be set from 5 to 100 meters. By pressing SEL the function starts blinking and you may select between on or off by pressing right or left. By pressing SEL the settings are confirmed.

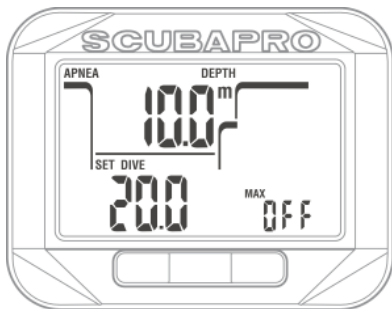

**NOTE:** The first alarm is short sequence for attention and the second alarm is continuous. By setting the first alarm deeper than the second, it will be masked by the continuous alarm and you cannot hear the first one.

### 1.4.2 Setting the depth incremental alarm

By pressing the SEL in this menu the incremental depth alarm starts blinking. By pressing right or left you may select the alarm value from 5 to 100 meters (20..330 feet). By pressing SEL the alarm value will be confirmed and the function at the bottom row starts blinking. By pressing right or left you may select the direction for the depth incremental alarm: off, dn(down), up or both. By pressing SEL the settings are confirmed.

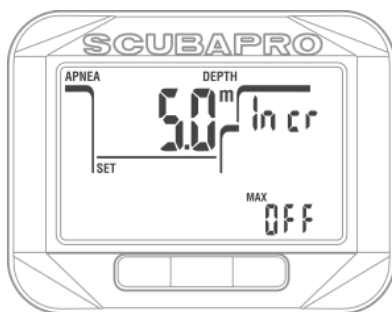

### 1.4.3 *Setting the dive time interval alarm*

By pressing SEL at this menu the dive time interval alarm starts blinking. By pressing right or left you can select the interval from 15 seconds up to 10 minutes in 15 second steps. By pressing SEL button the function starts blinking and you may select on or off by pressing right or left. By pressing SEL the settings are confirmed.

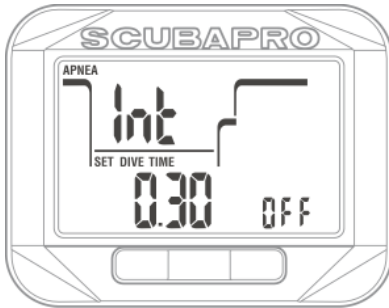

### 1.4.4 *Setting the surface interval alarm*

By pressing SEL button at this menu the surface interval time starts blinking. By pressing right or left you can select the interval from 15 seconds up to 10 minutes. By pressing SEL button the function blinking and you may select on or off by pressing right or left. By pressing SEL the settings are confirmed.

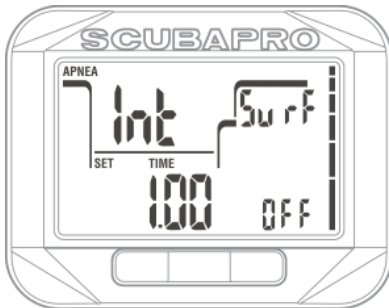

### 1.4.5 *Setting the low Heart Rate limit alarm*

In apnea diving a low heart rate is a key for low oxygen consumption and therefore for longer dives. However, too low of pulse at depth may lead to loss of awareness and can be therefore dangerous.

By pressing SEL at this menu the low heart rate alarm value starts blinking. By pressing right or left you can set the value from 25 to 100 beats per minute. By pressing SEL button the function starts blinking. By pressing right or left you may select between on or off. By pressing SEL the settings are confirmed.

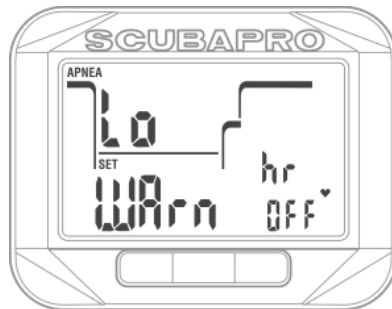

### 1.4.6 *Setting the Ascent speed alarm*

By pressing SEL at this menu the ascend speed starts blinking. By pressing right or left you may select the value from 0.1 to 5.0 meters/second (1..15 feet/second). By pressing SEL the function starts blinking. By pressing right or left you may select between on or off. By pressing SEL the settings are confirmed.

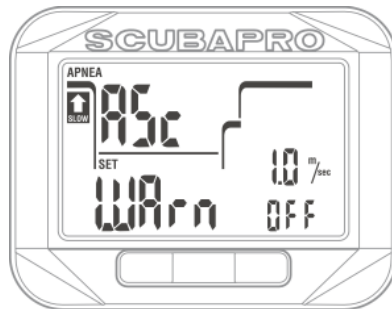

### 1.4.7 Setting the water density

When apnea diving the exact depth is very important value. For the most accurate reading you must select the correct density of the water. Density depends on water temperature and salinity (salt content). Some approximated densities at 20°C/68°F water.

- Average Ocean water has approximately 1.025 kg/liter.
- Mediterranean Sea has approximately 1.027 kg/liter.
- Red Sea has approximately 1.029 kg/liter.
- Black Sea has approximately 1.012 kg/liter.
- Baltic Sea has approximately 1.004 kg/liter.
- Fresh water (lake/quarry) has density approximately 1.000 kg/liter.

By pressing SEL at this menu the water density value starts blinking. By pressing right or left you may change the value from 1.000 to 1.050 in steps of 0.001. By pressing SEL the settings are confirmed.

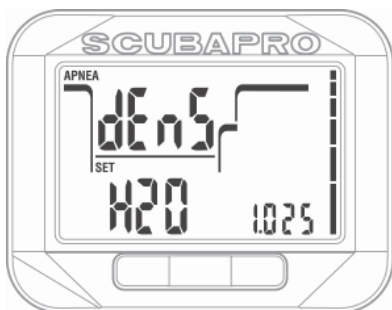

### 1.5 Set Up/Down Time Counter for the dive

There are many situations during a dive where a simple stop timer which is independent from dive time is practical; for example timed tasks at dive courses or special missions etc.

Square has a stop timer integrated on the SCUBA mode, **which has to be configured before the dive in this menu.** By pressing SEL at this menu the function starts blinking. By pressing right or left you may select between up, dn(down) or off. By pressing SEL the counter time starts blinking and you may set it from 5 second

up to 99 minutes and 55 seconds in 5 second steps by pressing right or left. By pressing SEL the settings are confirmed.

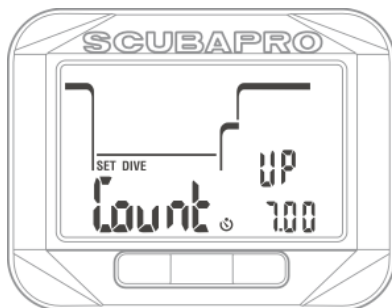

### 1.6 Algorithm selection

You may select your Square operation mode between SCUBA, Gauge and Apnea modes.

When Square has not been submerged for a while the display looks as follows:

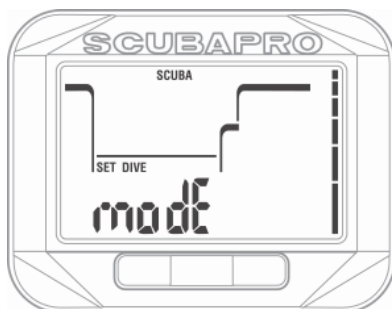

**Since the Gauge and Apnea modes are not tracking the tissue saturation, there is 48h locking interval after the last dive in gauge or apnea mode before change to a SCUBA mode is possible.**

After a SCUBA dive the limitation to change the mode is valid until desaturation is complete.

Square shown below has been dived in apnea mode and the NO CHANGE limitation is still on for another 47 hours.

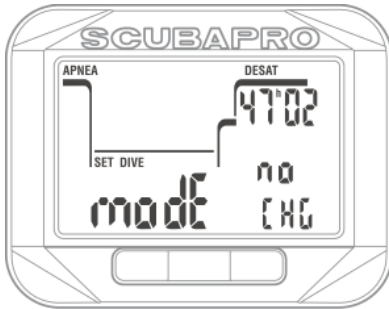

If you decide to change between modes before the 48h interval or full desaturation you have to go to desaturation reset menu and make a manual desaturation reset.

By pressing the SEL at this menu the mode starts blinking. By pressing right or left you may select between SCUBA, gauge or apnea modes. By pressing SEL the setting is confirmed.

### 1.7 HR enable

By pressing SEL at this menu the HR function starts blinking and by pressing right or left you may select between on or off. By pressing SEL the setting is confirmed.

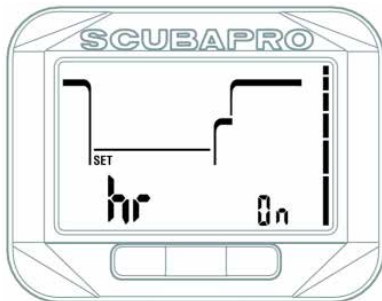

## 2. SQUARE AS A DIVE COMPUTER

Square is a full-featured diving computer, capable of multigas decompression calculations, ascent rate calculations and warnings. The logbook can store about 50 hours of dive profiles with a 4s sampling rate. During diving it displays depth, dive time, decompression status, water temperature and much more. On the surface after a dive, remaining desaturation time, no-fly time, surface interval and prohibited altitude classes are shown.

### 2.1 Diving with Square

The functions of the buttons during diving are summarized in the table below.

Note that Square can be set to three dive modes: Scuba, Apnea and Gauge. Due to the operation differences also buttons have different functions.

LEFT BUTTON			RIGHT BUTTON		
press	mode	action	press	mode	action
Short		backlight	Short	SCUBA	alternative display data
Long		bookmark	Long	SCUBA	select manual gas switch
Long	APNEA	manual stop the dive	Short	SCUBA	confirm selected gas switch
Long	SCUBA	start the "stop watch" counter	Short	SCUBA	reset safety stop timer
			Short	APNEA	switch between HR and dive number at that session
			Long	APNEA	manual start the dive
			Short	GAUGE	alternative display data
			Long	GAUGE	reset average depth counter and start/stop timer

## 2.2 Altitude diving

### 2.2.1 Altitude classes, altitude warning and no-fly time after a dive.

Going to altitude is in a way similar to starting an ascent from a dive: you expose your body to a lower partial pressure of nitrogen and consequently you start offgassing. After a dive, given the higher nitrogen loading in your body, even reaching an otherwise negligible altitude can potentially cause decompression sickness. Consequently, Square constantly monitors the ambient pressure and uses it to evaluate your nitrogen loading and offgassing. If Square notices a drop in ambient pressure not compatible with your current nitrogen loading, it will activate a warning to alert you of the potentially dangerous situation.

Square shows no fly, no dive and altitude warning symbols at the main time and date screen until the restrictions apply. The exact times can be viewed at desat screen.

Desat screen appears only after a dive or when an altitude class change has been detected.

Desat screen disappears after desaturation is complete. This screen shows the desaturation time at top row right.

The prohibited altitude (the altitude which Square has computed to be incompatible with your current nitrogen saturation levels) is shown at the desat screen upper row left until this limitation applies.

At the desat screen Square shows the no-fly time at bottom row left. The no-fly time is the time during which an exposure to the reduced pressure inside

the cabin of an airplane could cause decompression sickness, as calculated by the decompression model in the computer. By pressing SEL at the desat screen the display shows elapsed interval from the last dive and the CNS clock level in % value, unless it has counted down to 0%.

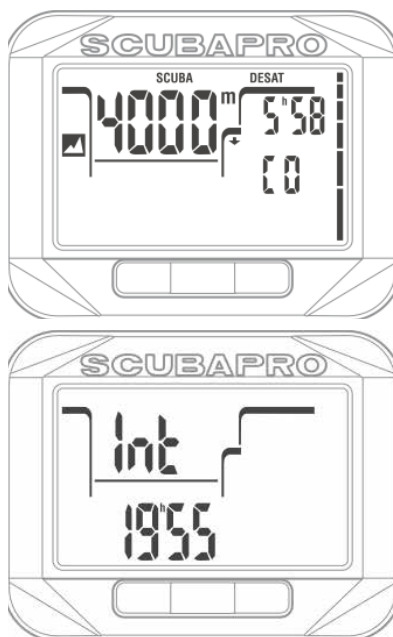

### **⚠ WARNING**

Flying while Square displays the **NO FLY** symbol can result in serious injury or death.

### 2.2.2 Altitude and the decompression algorithm

Atmospheric pressure is a function of altitude and of weather conditions. This is an important aspect to consider for diving, because the atmospheric pressure surrounding you has an influence on ongassing and offgassing of nitrogen. Above a certain altitude, the decompression algorithm has to change in order to account for the effect of the change in atmospheric pressure.

Square divides the possible altitude range in 5 classes that are illustrated on the picture below:

Altitude Class	Elevation	Barometric switch point	Dive computer mode
C4	4000 m 13120 ft	610 mbar 8.85 psi	GAUGE (no deco data)
C3	3000 m 9840 ft	725 mbar 10.51 psi	SCUBA
C2	2000 m 6560 ft	815 mbar 11.82 psi	SCUBA
C1	1000 m 3280 ft	905 mbar 13.13 psi	SCUBA
C0	0 m 0 ft		SCUBA

The altitude classes are defined in terms of approximate elevations because the effect of weather conditions can make the switch point pressure occur at different levels.

#### WARNING

**At altitude class 4 Square functions in gauge mode only (automatic switch from computer mode).**

**NOTE:** You can check your current altitude class and elevation by activating the altitude meter. Refer to chapter **Checking the Altitude** on how to do so.

**NOTE:** Square deals with altitude automatically: it monitors the atmospheric pressure every 60 seconds and if it detects a sufficient drop in pressure, it does the following: it shows the new altitude range at altimeter and, if applicable, the prohibited altitude range at desat screen; it indicates the desaturation time, which in this case is an adaptation time to the new ambient pressure. If a dive is started during this adaptation time, Square considers it a repetitive dive, since the body has residual nitrogen.

### 2.2.3 Prohibited altitude

Going to altitude, as well as flying after diving, exposes your body to a reduced ambient pressure. In a way similar to the no-fly time, Square advises you which altitudes are safe to reach after a dive and which aren't. If you have to drive over a mountain pass to return home after a dive, it can be quite important to have this information.

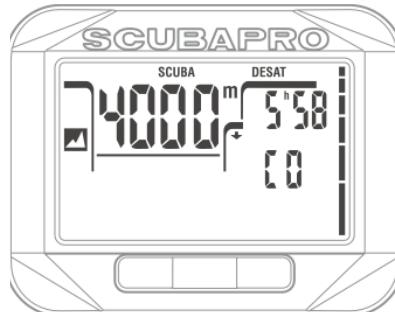

The prohibited altitudes are the ones above the elevation displayed at desat display. In the example above, the diver should not reach altitudes of greater than 4000m.

Square has an altitude warning: if you were to reach an altitude that according to Square is incompatible with your current residual nitrogen levels, it will warn you with an altitude warning.

### 2.2.4 Decompression dives in mountain lakes

In order to assure optimal decompression even at higher altitudes, the 3m/10ft decompression stage is divided into a 4m/13ft stage and a 2m/7ft stage in altitude ranges 1, 2 and 3.

If atmospheric pressure is below 610mbar (altitude higher than 4000m/13300ft), no decompression calculation is carried out by Square (automatic gauge mode). In addition, the dive planner is not available in this altitude class.

### 2.3 No-dive warning after a dive

If Square detects a situation of increased risk (due to the potential microbubble accumulation from previous dives or a CNS O<sub>2</sub> level above 40%), the **NO DIVE** symbol will appear on the display to advise you against performing another dive right away.

The suggested time interval that you should wait prior to diving can be checked with planner.

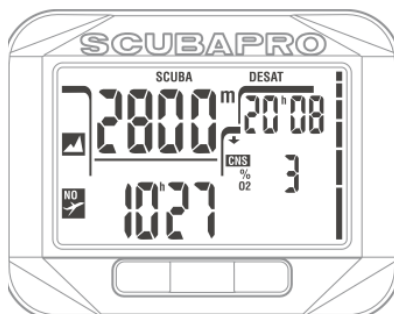

You should not undertake a dive as long as the no-dive warning is displayed on the computer screen. If the warning is prompted by microbubble accumulation (as opposed to CNS O<sub>2</sub> over 40%) and you dive anyway, you will have shorter no-stop times or longer decompression times. Moreover, the duration of the microbubble warning at the end of the dive can increase considerably.

## 2.4 SOS

If you stay above a depth of 0.8m/3ft for more than 3 minutes without observing a prescribed decompression stop, Square will switch into **SOS** mode. Once in **SOS** mode Square will lock up and will be inoperable as a dive computer for 24 hours. If it is used for diving within the 24hours of an **SOS** lock, it will automatically switch to gauge mode and provide no decompression information.

### ⚠ WARNING

Violating a mandatory decompression obligation may result in serious injury or death.

**Serious injury or death may result if a diver does not seek immediate treatment should any signs or symptoms of decompression sickness occur after a dive.**

**Do not dive to treat symptoms of decompression sickness.**

**Do not dive when the computer is in SOS mode.**

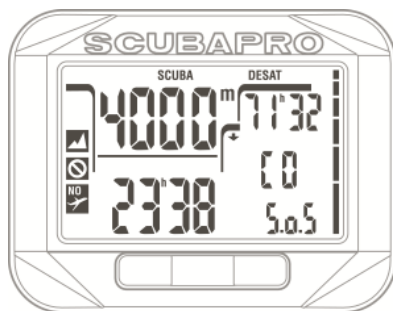

The desat display shows the same information as in presence of desaturation, but at the bottom right row SOS is blinking.

### 2.4.1 Desaturation reset

Square allows you to reset the desaturation in the computer. Any tissue saturation information from a recent dive will be reset to zero and the computer treats the next dive as a non-repetitive dive. This is useful when the computer is loaned to another diver who has not dived in the last 48 hours. Description how to make a desaturation reset is explained at chapter: **Gas settings; Desaturation reset.**

☞ *NOTE: After a desaturation reset the change between the modes: Gauge, Apnea and Scuba are possible immediately. However, since the gauge and apnea modes are not tracking your tissue nitrogen loading, it is recommended to keep the initial intervals between changes on modes.*

### **WARNING:**

**Diving after having reset the desaturation is extremely dangerous and is very likely to cause serious injury or death. Do not reset the desaturation unless you have a valid reason to do so.**

☞ *NOTE: Removing and replacing the battery will not reset the desaturation. Square stores tissue saturation information in non-volatile memory. For the time during which the computer is without battery, the desaturation calculation is frozen and resumes from where it had left off as soon as a new battery is installed.*

## 2.5 Diving with nitrox or with another decompression gas

Nitrox is the term used to describe breathing gases made of oxygen-nitrogen mixes with oxygen percentage higher than 21% (air). Because Nitrox contains less nitrogen than air, there is less nitrogen loading on the diver's body at the same depth as compared to breathing air.

However, the increase in oxygen concentration in Nitrox implies an increase in oxygen partial pressure in the breathing mix at the same depth. At higher than atmospheric partial pressures, oxygen can have toxic effects on the human body. These can be lumped into two categories: Sudden effects due to oxygen partial pressure over 1.4bar. These are not related to the length of the exposure to high partial pressure oxygen, and can vary in terms of the exact level of partial pressure they happen at. It is commonly accepted that partial pressures up to 1.4bar are tolerable, and several training agencies advocate

maximum oxygen partial pressures up to 1.6bar.

Long exposure effects to oxygen partial pressures over 0.5bar due to repeated and/or long dives. These can affect the central nervous system, cause damage to lungs or to other vital organs. Long exposures can be divided to more severe Central Nervous System effects and less dangerous long term Pulmonary Toxicity effects.

Square treats high ppO<sub>2</sub> and long exposure effects in the following ways:

Against sudden effects: Square has an MOD alarm set for a user-defined ppO<sub>2</sub>max. As you enter the oxygen concentration for the dive, Square shows you the corresponding MOD for the defined ppO<sub>2</sub>max. The default value of ppO<sub>2</sub>max from the factory is **1.4bar**. This can be adjusted to your preference between **1.0** and **1.6bar**. It can also be turned **OFF**. Please refer to chapter **Gas settings** for more information on how to change this setting.

Against long exposure effects: Square "tracks" the exposure by means of the CNS O<sub>2</sub> clock. At levels of 100% and higher there is risk of long exposure effects, and consequently Square will activate an alarm when this level of CNS O<sub>2</sub> is reached. Square can also warn you when the CNS O<sub>2</sub> level reaches 75% (see section CNS alarm). Note that the CNS O<sub>2</sub> clock is independent of the value of ppO<sub>2</sub>max set by the user.

The CNS O<sub>2</sub> clock increases when the oxygen partial pressure is higher than 0.5bar, and decreases when the oxygen partial pressure is lower than 0.5bar. Hence, while on the surface breathing air you will always be decreasing the CNS O<sub>2</sub> clock. During the dive, the depth at which 0.5bar is reached for various mixes is as follows:

Air:	13m/43ft
32%:	6m/20ft
36%:	4m/13ft

☞ *NOTE: The O<sub>2</sub> concentration of gas d can only be set to a value higher than the O<sub>2</sub> concentration for gas 1. Square requires that the MODs of gas 1 and gas d be at least 3m/10ft apart. Setting the ppO<sub>2</sub>max value to **OFF** applies to gas 1 only. Gas d is always limited to*



a maximum value of  $ppO_2$  max of **1.6bar**. For oxygen concentrations of 80% and higher, the  $ppO_2$  max is fixed at **1.6bar** and cannot be changed. The MOD for gas **d** is the switch depth for that gas. This is what Square uses for its calculation, warnings and suggested switch point. When diving with more than one gas mixture, the Nitrox reset time function (described in section 2.3.5) has the following effect:

Gas **1** is set to 21%

Gas **d** is set to **OFF**.

### 2.5.1 Diving with more than one gas mix

Square is equipped with the ZH-L8 ADT MB PMG algorithm. PMG stands for Predictive Multi Gas, meaning that when you program more than one gas mixture, Square will predict the switch to the higher oxygen concentration gas at the depth that you specified and alert you at all times with a decompression schedule comprehensive of both gas mixtures that you programmed. In other words, you get full credit at any point during the dive for all the extra gas that you are carrying with you. At the same time Square can also show you what the decompression schedule would be if you were to finish the dive using only the gas mixture that you are currently breathing from, so that you can be prepared in the event that something did not work as planned.

#### **⚠ WARNING:**

Diving with two gas mixtures represents a much higher risk than diving with a single gas mixture and mistakes by the diver may lead to serious injury or death.

During dives with two gas mixtures, always make sure you are breathing from the tank that you intend to breathe from. Breathing from a high oxygen concentration mix at the wrong depth can kill you.

Mark all your regulators and tanks so that you cannot confuse them under any circumstance. Before each dive and after changing a tank, ensure that each gas mixture is set to the correct value for the corresponding tank.

Get a proper training and certifications to accomplish multigas dives prior of making them.

Square enables you to use up to two gas mixtures during the dive (air and Nitrox only). The two mixtures are labeled **1** and **d**, and must be in ascending order of oxygen content.

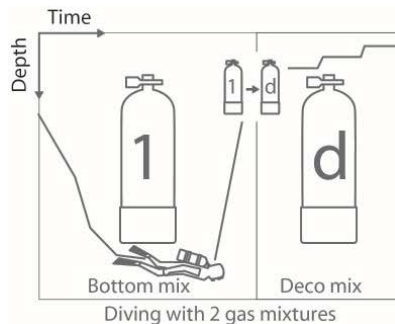

#### 2.5.1.1 Switching gas mixture during the dive

During the ascent phase, when you reach a depth corresponding to the MOD of gas **d**, Square will suggest that you perform the switch. An audible sequence goes off, and the text **gas d** starts blinking. You have 30 seconds to respond to this message, otherwise Square will consider that gas **d** will not be used and adapts the decompression schedule accordingly. To confirm the gas switch, **press SEL button**.

**👉 NOTE:** Start breathing from the tank with the new gas mixture before confirming a switch:

#### **⚠ WARNING:**

Always make sure you are switching to the intended gas. Failure to do so may result in serious injury or death.

After you confirm the switch, the text **gas d** remains on the screen.

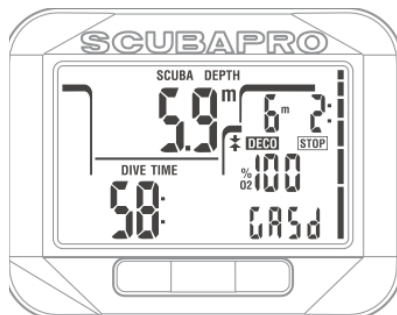

### 2.5.1.2 Switching back to a gas mixture with lower oxygen concentration

There may be situations in which you have to switch back to gas **1** from gas **d**. This can happen for instance if you want to descend again below the MOD for gas **d**, or if for instance you have run out of gas **d** during the decompression. At this point you can manually initiate the gas switch by **pressing SEL** button. Square will display the text **gas 1**, blinking. At this point **press SEL button** to confirm the switch. Square will display the text **gas 1** and adapt the decompression schedule accordingly.

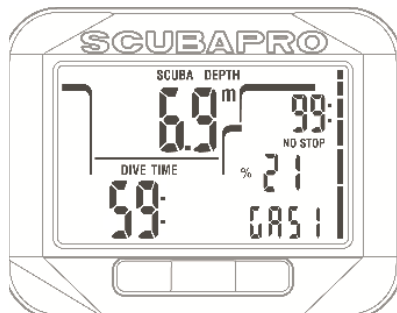

### 2.5.1.3 Gas switch not carried out at the planned depth

If you fail to confirm the change to gas **d** within the 30 seconds of when Square suggested it, gas **d** is excluded from the decompression calculation and the decompression schedule is adapted accordingly, basically reflecting the fact that you will finish the dive using gas **1** only.

**NOTE:** if after Square has changed the decompression schedule to reflect the missed gas switch, you descend again below the MOD for gas **d**, Square reintroduces gas **d** into the calculations and the decompression schedule changes accordingly.

### 2.5.1.4 Delayed gas switch

You can catch up on a planned gas mixture switch at any time by selecting the gas manually. **Press SEL** button to start the gas switch procedure. Square will show the text gas **d** and its MOD blinking on the display. This helps you verify that you are performing a switch to a safe gas. At this point **press SEL button** to confirm the switch. Square will display the text **gas d** without blinking and adapt the decompression schedule accordingly.

### 2.5.1.5 Manual gas switch at a depth deeper than its MOD

There may be situations in which you have no other choice but to switch to a gas mixture although you are below the MOD for that mixture. Square does not prevent you from doing this, but the MOD alarm will immediately start. **Press SEL** button to start the gas switch procedure. Square will show the text **gas d** blinking on the display. This helps you verify that you are performing a switch to a safe gas. At this point **press SEL button** to confirm the switch.

### 2.5.1.6 Submerging below the MOD after a gas switch

If after having switched to gas **d** you inadvertently drop again below the MOD for that mixture, the MOD alarm will immediately start. Either switch back to gas **1**, or ascend above the MOD for gas **d**.

## 2.6 Warnings and alarms

Square can alert you of potentially dangerous situations via warnings and alarms. **You can only modify the warning and alarm settings via PC interface.**

## ▲ WARNING:

represent situations that require the diver's attention, but ignoring them does not represent an immediate risk. It is up to you to decide which ones you would like to be active and which ones not. The available warnings are:

### 2.6.1 CNS O<sub>2</sub> = 75%

Square tracks your oxygen uptake via the CNS O<sub>2</sub> clock. If the calculated value of CNS O<sub>2</sub> reaches 75%, Square will emit a sequence of audible beeps for 12 seconds and the value of the CNS O<sub>2</sub> will be blinking in the lower right corner. The blinking will continue until the value of CNS O<sub>2</sub> drops under 75%.

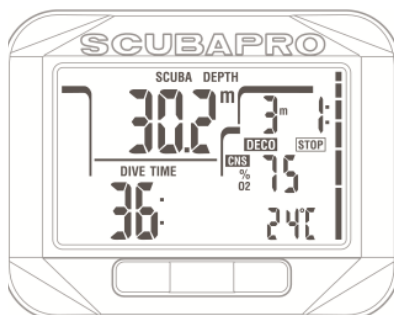

### 2.6.2 No-Stop time = 2 minutes

If you wish to avoid unintentionally performing a decompression dive, Square can activate a warning when the no-stop time reaches 2 minutes. This applies to both L0 no-stop and MB no-stop time (see chapter Diving with MB levels for more information on MB level diving). It gives you the opportunity to start ascending before incurring a decompression stop or a level stop obligation.

Square emits a sequence of audible beeps for 12 seconds and the no-stop time will blink. The blinking will continue until you ascend sufficiently for the no-stop time to grow to 3 minutes, or until Square enters into decompression.

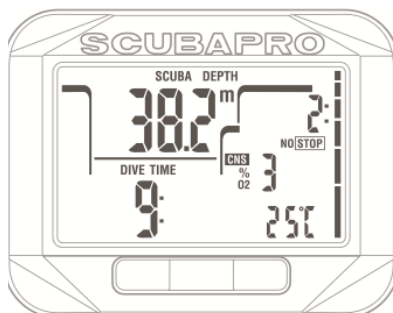

### 2.6.3 Entering decompression

Square can activate a warning when the first mandatory decompression stop appears. This alerts the diver to the fact that a direct ascent to the surface is no longer possible. This warning applies to dives with the computer set to L0 only.

Square emits a sequence of audible beeps and the DECO STOP symbol blinks, both for 12 seconds, when the no-stop time ends and a mandatory (L0) stop is required before reaching the surface.

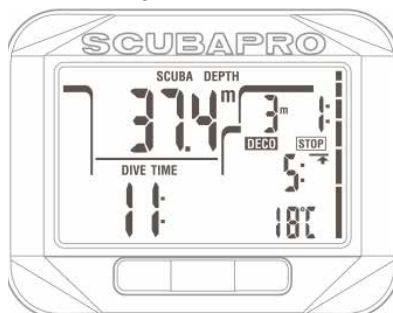

### 2.6.4 Entering level stops

When diving with a microbubble (MB) level different than L0, Square can warn you when you are no longer in the MB no-stop phase. See section 2.7.5 Diving with MB-Levels for more information on MB level diving.

Square emits a sequence of audible beeps and the STOP symbol blinks, both for 12 seconds, when the MB no-stop time ends and a level stop is required before you ascend to the surface.

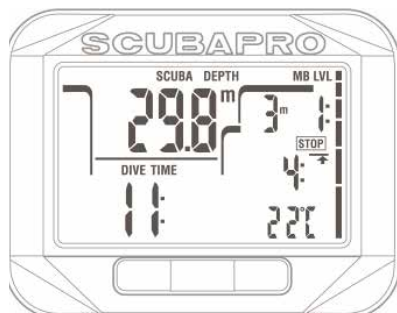

### 2.6.5 L0 no stop time = 2 minutes when diving an MB level

When diving with an MB level higher than L0, the underlying L0 information is not directly visible on the display (though it is accessible as alternate information). You can choose to have Square warn you when the underlying L0 no-stop time reaches 2 minutes while diving with an active MB level higher than L0.

Square emits a sequence of audible beeps and the MB LVL symbol blinks, both for 12 seconds, when the L0 no-stop time reaches 2 minutes while diving with an active MB level higher than L0.

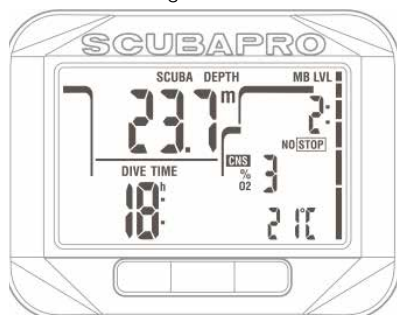

### 2.6.6 Entering deco when diving an MB level

When diving with an MB level higher than L0, the underlying L0 information is not directly visible on the display (though it is accessible as alternate information). You can choose to have Square warn you when you are about to enter a decompression obligation while diving with an active MB level higher than L0.

Square emits a sequence of audible beeps and the DECO STOP symbol blinks, both for 12 seconds, when the L0 no-stop time ends while diving with an active MB level higher than L0.

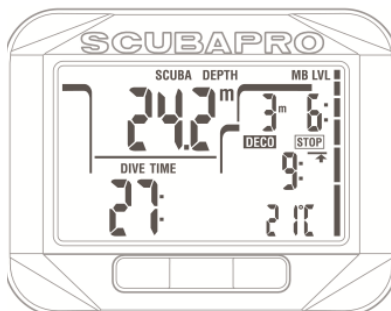

Alarms can not be turned off because they represent situations that do require immediate action by the diver. There are five different alarms:

### WARNING:

- When in gauge mode, all warnings and all alarms are OFF aside for the low battery alarm.
- When Square is set to SOUND OFF mode, all audible alarms and warnings are switched off.

### 2.6.7 Ascent rate

As you ascend during a dive, the pressure surrounding you diminishes. If you ascend too quickly, the ensuing pressure reduction could lead to microbubble formation. If you ascend too slowly, the continued exposure to high ambient pressure means that you will continue loading some or all of your tissues with nitrogen. Consequently, there is an ideal ascent rate that is slow enough to minimize microbubble formation yet fast enough to minimize the effect of continued loading on your tissues.

The pressure reduction that the body can tolerate without significant microbubble formation is higher at depth than it is in the shallows: The key factor is not the pressure drop by itself, but rather the ratio of the pressure drop relative to the ambient pressure. This means that the ideal ascent rate at depth is higher than it is in the shallows.

Along these lines, Square employs a variable ideal ascent rate: its value ranges

between 7..20m/min / 23..66ft/min and the actual breakdown by depth range is listed in the chart below.

DEPTH		ASC SPEED	
m	ft	m/min	ft/min
0	0	7	23
6	20	8	26
12	40	9	29
18	60	10	33
23	75	11	36
27	88	13	43
31	101	15	49
35	115	17	56
39	128	18	59
44	144	19	62
50	164	20	66

If the ascent rate is greater than 110% of the ideal value the **SLOW** symbol appears. For ascent rates higher than 140%, the **SLOW** symbol starts to blink.

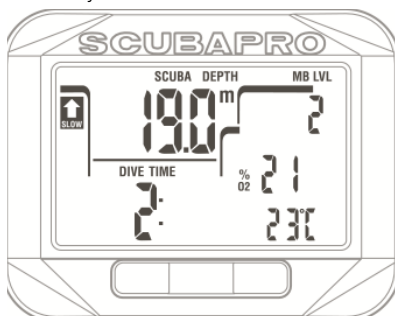

Square also provides an audible alarm in case of ascent rates exceeding 110%: the intensity of the alarm increases in direct proportion to the degree that the ideal ascent rate is exceeded.

In case of a fast ascent, Square may require a decompression stop even within the no-stop phase because of the danger of microbubble formation.

From great depth a slow ascent may cause heightened saturation of tissues and an extension of both decompression duration and total ascent time. At shallow depth, a slow ascent may shorten the decompression duration.

Excessive ascent rates for longer periods are entered in the logbook.

### ⚠ WARNING:

The ideal ascent rate must not be exceeded at any time since this could lead to microbubbles in the arterial circulation which could cause serious injury or death.

The alarm persists for as long as the ascent rate is 110% or more of the ideal ascent rate.

#### 2.6.8 MOD/ppO<sub>2</sub>

### ⚠ WARNING:

- The MOD should not be exceeded. Disregarding the alarm can lead to oxygen poisoning.
- Exceeding a ppO<sub>2</sub> of 1.6bar can lead to sudden convulsions resulting in serious injury or death.

If you exceed the MOD, the depth will start to blink and in the bottom row the MOD is displayed so you can see by how much you have exceeded it. In addition, Square will beep incessantly. Both the blinking of the depth value and the beeping will continue for as long as you stay deeper than the MOD.



#### 2.6.9 CNS O<sub>2</sub> = 100%

### ⚠ WARNING:

When the CNS O<sub>2</sub> reaches 100% there is danger of oxygen toxicity. Start procedure to terminate the dive.

Square tracks your oxygen uptake via the CNS O<sub>2</sub> clock. If the calculated value of CNS O<sub>2</sub> reaches 100%, Square will emit a sequence of audible beeps for 12 seconds and the value of the CNS O<sub>2</sub> will be blinking in the lower right corner. The blinking will continue until the value of CNS O<sub>2</sub> drops under 100%.

The audible signal is repeated for 5 seconds in one minute intervals after the first occurrence and for as long as the value of CNS O<sub>2</sub> stays at or above 100% or until the ppO<sub>2</sub> drops under 0.5bar (see chapter **Diving with nitrox or with another decompression gas** for a list of depths at which ppO<sub>2</sub> equals 0.5bar for some typical Nitrox mixes).

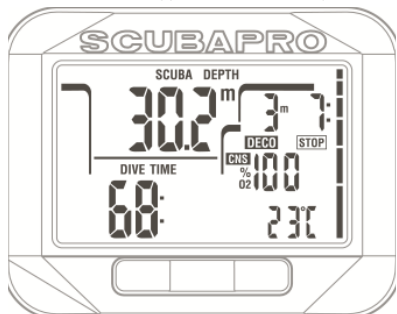

### 2.6.10 Missed decompression stop

#### **⚠ WARNING:**

**Violating a mandatory decompression obligation may result in serious injury or death.**

If in presence of a required decompression stop you ascend more than 0.5m/2ft above the required stop, Square will trigger an alarm: the value of the current depth and the value of the required stop depth will blink, and a sequence of beeps can be heard. This will continue for as long as you stay 0.5m/2ft or more above the required stop.

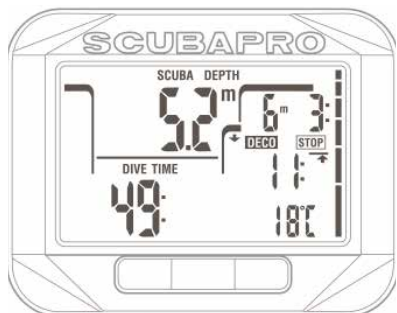

### 2.6.11 Low battery

#### **⚠ WARNING:**

**Do not start a dive if the battery symbol is displayed on the screen. The computer may fail to function during the dive and this could lead to serious injury or death.**

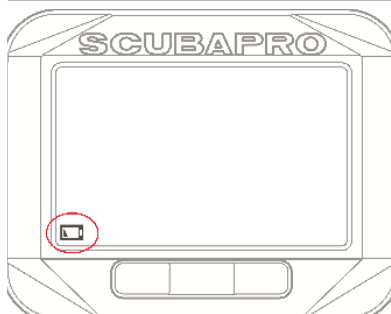

During the dive, Square alerts you of precarious battery situation by displaying a steady battery symbol on the screen. This means you can finish the dive but you should replace the battery once you return to the surface.

## 2.7 Display information

Upon immersion, Square will automatically start to monitor the dive regardless of what state it was in prior to the immersion. Details on the information displayed can be found in the next sections.

The dive time is displayed in minutes. If during the dive you ascend to the surface, the time spent on the surface will only be counted if you descend again below 0.8m/3ft within 5 minutes. This allows for brief periods of orientation. While on the surface, the time will not show as progressing but it is running in the background. As soon as you submerge, the time will resume, including the time spent on the surface. If you spend more than 5 minutes at depth shallower than 0.8m/3ft, the dive will be considered ended, the logbook closed and a subsequent immersion would cause the dive time to start again from zero.

Maximum displayed time is 199 minutes. For dives longer than that, the dive time starts again from 0 minutes.

Depth: the depth is given in 10cm resolution when metric mode. When the depth is displayed in feet, the resolution is always 1 foot. At a depth shallower than 0.8m/3ft, the display shows --. Maximum possible depth is 120m/394ft.

No-stop time: calculated in real time and updated every 4 seconds. Maximum displayed no-stop times is 99 minutes.

### **⚠ WARNING:**

**During all dives, perform a safety stop between 3 and 5 meters/10 and 15 feet for 3 to 5 minutes, even if no decompression stop is required.**

Temperature: Square displays the water temperature during the dive and the air temperature on the surface. However, the skin temperature influences the measurement when worn at the wrist.

Decompression information: when Square calculates the need for a mandatory decompression stop, it shows you how long and how deep your deepest stop is. It also gives you the total ascent time. Stops deeper than 27m/90ft and total ascent times longer than 99 minutes are shown as "- -".

Decompression information at MB L0: if you are diving with an MB level different than MB L0, you can ask Square to show you the decompression information pertinent to the underlying MB L0 calculation. For more information on MB levels, please refer to chapter Diving with MB levels.

#### **2.7.1 Display configuration during the dive**

Throughout the dive, Square displays the current depth (top row left), the elapsed dive time (bottom row left) and the no-stop or decompression information (top row right).

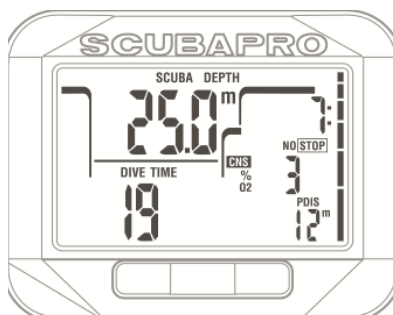

In addition, Square utilizes the alternate displayed data at middle and bottom row right regarding the dive. By **pressing** right button will show, in sequence:

1. PDIS depth (when pending)
2. Maximum depth (only if 1m/3ft ascent detected)
2. Water temperature
3. Heart rate (if activated)
4. O<sub>2</sub> %
  - a. MOD of the active gas (if gas d enabled)
  - b. If gas 1 active then bail out info using only gas 1 **at the middle row**
  - c. Active MB level
  - d. No-stop or decompression information at L0 (displayed in middle row, only if diving with an MB level other than L0)
5. CNS % if greater than 1%
6. Time of the day **in the bottom row** for 5 seconds (temperature at bottom row right).

#### **2.7.2 Setting bookmarks**

By **press and hold** LIGHT button you can set any number of bookmarks as reminders of particular moments during the dive. The bookmarks will appear on the dive profile in LogTRAK.

**☞ NOTE:** If the "stop watch" counter has been enabled the long press left will activate it.

### 2.7.3 Safety stop timer

If a minimum depth of 10m/30ft has been reached during the dive, at a depth of 5m/15ft the safety stop timer will start according to settings either automatically or you may start this by pressing a button. If you go below 6.5m/20ft, the timer will disappear and the no-stop time is shown again. Upon returning to 5m/15ft, the timer will start again if set to automatic. As long as you are shallower than 6.5m/20ft and there are no decompression obligations, you can **press** left button to restart the countdown manually.

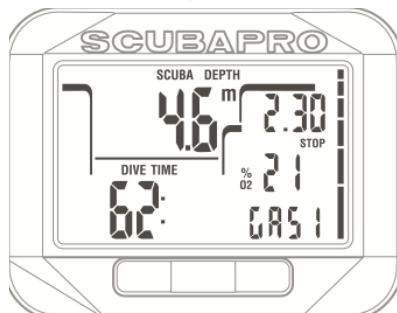

### 2.7.4 Activating the backlight

To activate the backlight, **press left**. The default duration of the backlight is **6 seconds**, but you can set a custom backlight duration time at dive settings. Read chapter **Setting the Backlight on duration**, about how to do this.

 **NOTE:** The backlight is not available when the **BATTERY CHANGE** warning appears.

### 2.7.5 Diving with MB levels

Microbubbles are tiny bubbles that can build up inside a diver's body during any dive and normally dissipate naturally during an ascent and on the surface after a dive. Dives within no-stop time and observance of decompression stops do not prevent the formation of microbubbles in the venous blood circulation. Square has been equipped with an enhanced UWATEC algorithm, named ZH-L8 ADT MB, to reduce the formation of these microbubbles.

This enhanced algorithm allows the user to choose a level of conservatism over and in addition to the worldwide proven safety record of the standard ZH-L8 ADT algorithm. There are five levels of added conservatism (or MB levels), from L1 to L5, with L5 being the most conservative and L1 being just a bit more conservative than the standard ZH-L8 ADT, here referred to as L0.

Choosing a MB level between L1 and L5 makes the algorithm more conservative, therefore the diver will have either shorter no-stop times or deeper and longer decompression stops (referred to as level stops) than when diving with L0. Consequently the body will either take up less nitrogen (shorter no-stop dives) or will be able to off-gas more before returning to the surface (dives with level stops). Both work towards reducing the amount of microbubbles present in the body at the end of the dive.

Please refer to chapter **Setting the Micro Bubble level** for information on setting the MB level.

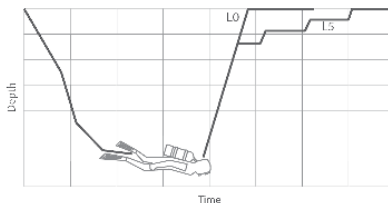

### 2.7.6 Display information

When diving with a MB level other than L0, Square still carries out all calculations relating to L0 in the background. To understand the relation between set MB level and the underlying L0 calculation and how the information appears on the display, we shall use the example of a dive with MB L3 set in the dive computer.



L3 information on display	L0 information in background	Display details
No-stop	No-stop	Display shows L3 no-stop time.
Level stop	No-stop	Display shows L3 level stop information. The white <b>STOP</b> symbol appears on the display.
Level stop	Decompression	Display shows L3 level stop information. In addition to the white <b>STOP</b> symbol, also the black <b>DECO</b> symbol appears to indicate that also L0 is in decompression.

### 2.7.7 Display of underlying L0 decompression information

During the dive, the information displayed is always relative to the active MB level. However, the underlying L0 data is available as one of the alternate information fields. When pressing the **right** button the appropriate number of times, the L0 information will be visible instead of the active MB level information for 5 seconds, after which it is replaced again by the information relative to the active MB level. While the L0 information is shown, the symbol **L0** appears in the middle row of the display. This allows you to be aware of what the maximum possible no-stop time is or what the mandatory decompression requirements are.

### 2.7.8 Cascading MB levels

When diving with an MB level, Square carries out all calculations relating to L0 and to all MB levels in between the currently active one and L0. This gives the diver the flexibility to start with a given MB level but to cascade down to a less conservative level during the dive: if you start the dive at L4 but decide not to carry out all the required L4 stops, you can cascade down through L3, L2, L1 all the way to L0. Only decompression stops relating to L0 are mandatory and must be respected at all times, whereas the level stops calculated by the MB levels are recommended but not mandatory.

### 2.7.9 Level stop ignored/MB level reduced

If a level stop is required and you ascend 1.5m/5ft or more above it, Square will reduce your active MB level to the next one compatible with the current depth. When this happens, the new active MB level is

permanently displayed on the screen. It is no longer possible to finish the dive with the MB level set at the beginning of the dive. When the level stop depth is the same as the deco stop depth, ascending 1.5m/5ft above it will cause Square to cascade down to L0.

At the end of the dive, for five minutes after reaching the surface, the active (reduced) MB level is shown on the display. After five minutes Square changes to surface mode and switches back to the MB level set prior to the dive.

### 2.7.10 PDI Stops

Square is equipped with the innovative Profile Dependent Intermediate Stops introduced on other Uwatec dive computers.

PDI Stop optimizes the leading compartment off gassing with a low gradient at depth which is calculated from the current profile.

After the dive profile has reached a level where PDI Stop is recommended the Square shows symbol PDIS on the bottom row right followed by the suggested stop depth.

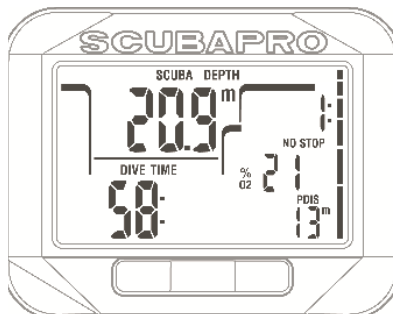

When ascending to a PDI stop depth the PDIS symbol starts blinking and 2 minute down time counter starts running.

Once PDIS depth has been reached, you should stay on the zone that is -0.5m..+3.0m / -2ft..+10ft from the shown PDIS depth. If you descend below this zone the PDIS counter will be deactivated and Square calculates a new PDIS depth.

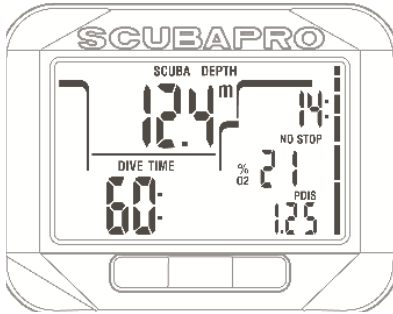

### ⚠ WARNING:

Even when performing a PDI stop, you still **MUST** perform a safety stop at 5m/15ft for 3 to 5 minutes. Performing a 3 to 5 minute stop at 5m/15ft at the end of any dive is still the best thing you can do for yourself!

## 2.8 Gauge mode

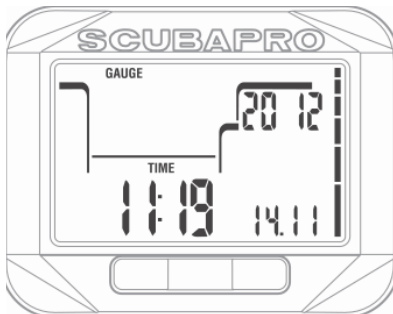

When Square is set to gauge mode, it will only monitor depth, time, and temperature, and will not carry out any decompression calculations. You can only switch to gauge mode if the computer is completely desaturated. All audible and visual warnings and alarms, other than the low battery alarm, are turned off.

### ⚠ WARNING:

**Dives in gauge mode are performed at your own risk. After a dive in gauge mode you must wait at least 48 hours before diving using a decompression computer.**

When on the surface in gauge mode, Square will show neither the remaining desaturation time nor the CNS O<sub>2</sub>% value. It will however display a surface interval up to 24 hours and a 48 hour no-fly time. This no-fly time is also the time during which you cannot switch back to computer mode.

The gauge mode surface display after a dive shows the dive time at the bottom row left. In the top row right the stopwatch is running from the dive start or last manual restart. On the bottom row right the maximum depth of the dive is shown. After 5 minutes timeout the display changes to gauge menu mode.

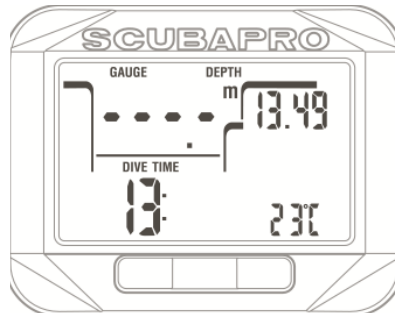

During a dive in gauge mode, Square displays a dive time in the bottom row left.

The stop counter is shown at the top row right and it can be reset and restarted by **pressing SEL button**.

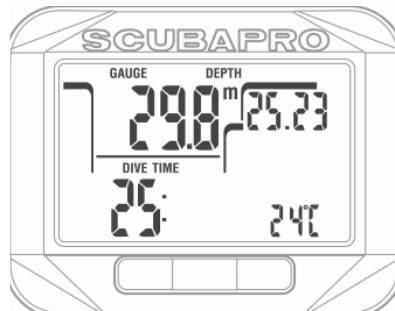

While in gauge mode, the average depth can be reset. To reset the average depth, **press and hold left** button.

As in SCUBA mode, **press right** to view the time of day for 5 seconds in the bottom row left and other alternative information at the bottom row. In the display below the time of the day has been selected (23:43) combined with average depth (12.8m).

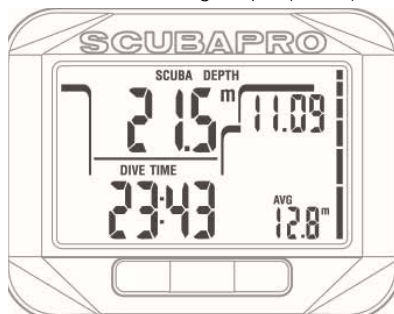

Alternative info can be selected in the following order:

1. Temperature
2. Average depth
3. Max depth
4. Current time of the day **at the bottom row left** (replaces the dive time for 5 seconds)

## 2.9 Apnea mode

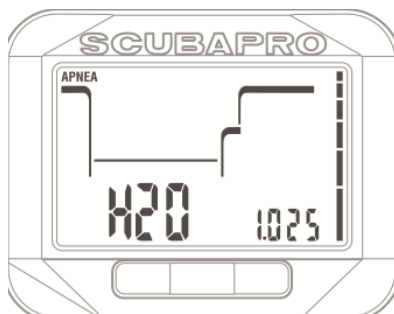

Square has an advanced Apnea diving mode. The main features include faster sampling rate than in normal SCUBA mode and alarm functions tailored to Apnea diving.

Square measures the depth in Apnea mode every 0.25 seconds to ensure the precise maximum depth. In logbook the

data is saved in 1 second intervals. The higher amount of saved data requires more space and the consequence is that approx 10 hours of log data can be stored in Apnea mode.

In Apnea mode it is also possible to start and stop the dive manually by pressing the SEL in dive set summary display. This way you can use the Square for static apnea dives, where normal dive start depth of 0.8 meters will not start a new dive.

As with gauge mode, Square doesn't carry out any decompression calculation. You can only switch to apnea mode if the computer is completely desaturated.

Apnea mode at surface after a dive shows the maximum depth at top row left and the dive duration at bottom row left.

The surface interval time is counting at the top row right for 15 minutes and if no repetitive dive is done the Square turns to dive set summary display.

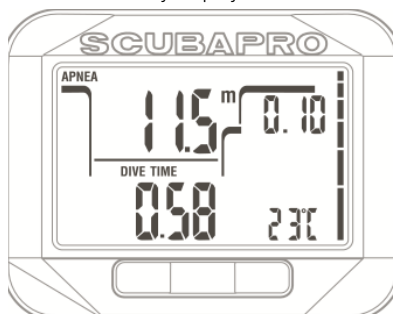

Apnea mode during the dive shows at top row left the current depth, at bottom row left the time, at bottom row right the HR and at the middle row right the ascent/descent speed.

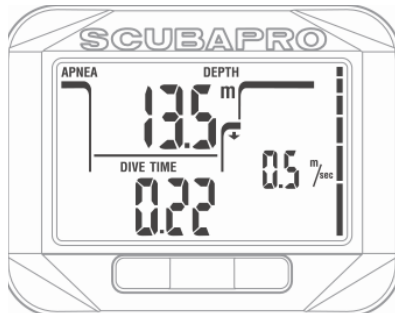

Alternative information can be selected by pressing right button. The information can be scrolled in following order:

1. Sequential dive number
2. Heart rate (if activated)

### 3. SQUARE ACCESSORIES

#### 3.1 HR belt

Square receives the signal of the various low frequency heart rate belts, for example Polar or Scubapro belts. The position to wear a HR belt is shown below.

Adjust the strap so that it is comfortable to wear but so that it holds on the place.

When using a diving suit the HR belt must be directly against the skin.

Moisten the electrode areas if your skin is dry or when using a dry suit.

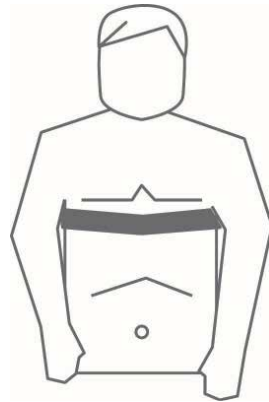

You must enable the heart rate setting on your Square, refer to chapter **Set HR limits (Workload settings)** of how to do this.

After a dive rinse the heart rate belt in fresh water, dry it and store on a dry place.

With completely sealed HR belts the battery cannot be changed.

We recommend having the battery change by authorized SCUBAPRO Uwaterc dealer for the HR belts with a battery cap.

Check the operation conditions and depth rating of the HR belt from the unit or its package.

## 4. SQUARE PC INTERFACE

### 4.1 Shark

The communication between Square and PC/Mac is possible only with a Shark.



The communication between the Square and the Shark is established via the contacts on the case bottom. Therefore if the water contacts or the spring contacts of the cradle have dirt on the surface, this should be cleaned with a piece of clothing before use.

### 4.2 Introduction to SCUBAPRO LogTRAK

LogTRAK is the software that allows Square to communicate with a Windows-based PC or Mac OS.

In order to take advantage of any of these features, you need to establish a communication between your PC and Square with a cradle.

To start the communication

1. Connect the Shark to your PC
2. Launch LogTRAK on your PC
3. Connect the Shark to your Square



4. Confirm the connection at Square by pressing right, the successful connection is indicated by a light on the Shark.

5. Select USB device Square  
Extras -> Options -> download

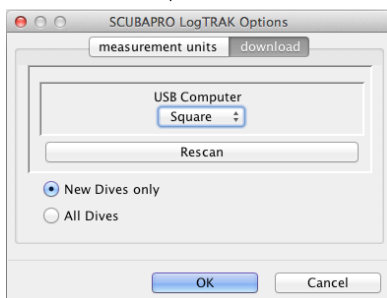

#### 4.2.1 Download dive profiles

From LogTRAK, by selecting Dive -> Download Dives you can transfer the Square Logbook to your PC or Mac.

**There are three main views each showing a specific part of your dive logs:**

**Profile** showing the graphical data of the dive.

**Details** about the dive, where you can edit for example the equipment and tank information.

**Location**, which shows your dive site at the world map.

The selection tabs for views are on the top of the main window.

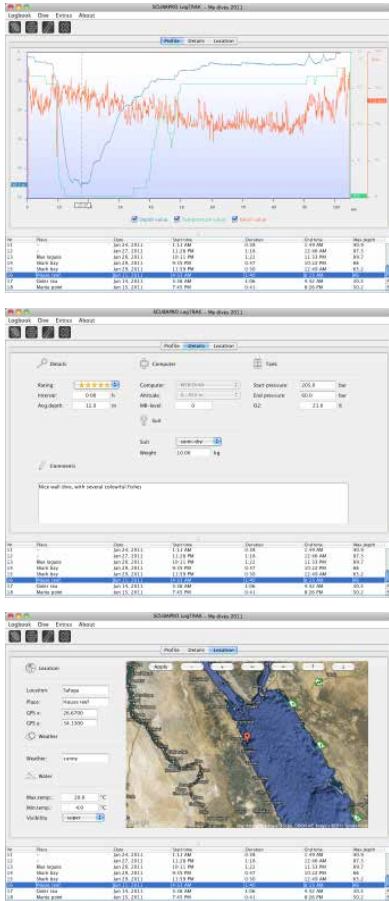

## 4.2.2 Change warnings/settings of the Square and reading computer info

By selecting Extras -> Computer settings you can enable/disable warnings that cannot be changed at Square unit via menus.



Read chapter **Warnings and alarms** about the possible selections that you can modify on your Square.

You may also change the shown units between metric/imperial. Select Extras -> Options -> measurement units:

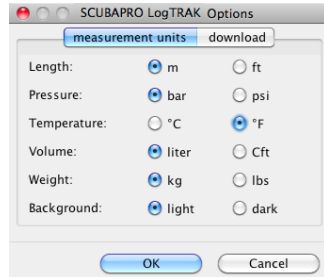

## 5. TAKING CARE OF SQUARE

### 5.1 Technical information

Operating altitude:

with decompression – sea level to approximately 4000m/13300ft without decompression (gauge mode) – at any altitude

Max operating depth:

120m/394ft; resolution is 0.1m until 99.9m and 1m at depth deeper than 100m. Resolution in ft is always 1ft. Accuracy is within 2%  $\pm$ 0.2m/1ft.

Decompression calculation range:

0.8m to 120m / 3ft to 394ft

Clock:

quartz clock, time, date, dive time display up to 199 minutes

Oxygen concentration:

adjustable between 21% and 100%

Operating temperature:

-10C to +50C / 14F to 122F

Power supply:

CR2450 lithium battery

Life of the battery:

About 2 years or 300 dives, which ever comes first. Actual battery life depends on the number of dives per year, the length of each dive, the water temperature, the usage of backlight and heart rate.

### 5.2 Maintenance

The depth accuracy should be verified every two years, that can be done by authorized SCUBAPRO dealer. Besides this, Square is virtually maintenance free. All you need to do is rinse it carefully with fresh water after each dive and change the battery when needed. To avoid possible problems with your Square, the following recommendations will help assure years of trouble free service:

- avoid dropping or jarring your Square
- do not expose Square to intense, direct sunlight
- do not store Square in a sealed container, always ensure free ventilation

If there are problems with the water contact, use soapy water to clean Square and dry it thoroughly. Do not use silicone grease on the water contacts!

- Do not clean Square with liquids containing solvents.
- Check the battery capacity before each dive.
- If the battery warning appears, replace the battery.
- If any error message appears on the display, take Square back to an authorized SCUBAPRO UWATEC dealer.

### 5.3 Replacing the battery in Square

#### WARNING:

**We recommend having the battery of Square replaced by an authorized SCUBAPRO UWATEC dealer. The change must be made with particular care in order to prevent water from seeping in. The warranty does not cover damages due to an improper placement of the battery.**

Square stores the tissue saturation information in non-volatile memory, so the battery can be replaced at any time between dives without loss of information.

 **NOTE:** - After a dive, Square stores tissue desaturation data once an hour while on the surface until it is completely desaturated. If battery is changed while Square has remaining desaturation time, the tissue data will not be lost, but Square will reference the last stored data set. As a consequence, the data displayed on the surface screen after the battery change (desaturation time, surface interval, no-fly time and CNS O<sub>2</sub>) may

be different from the values displayed just prior to the battery removal.

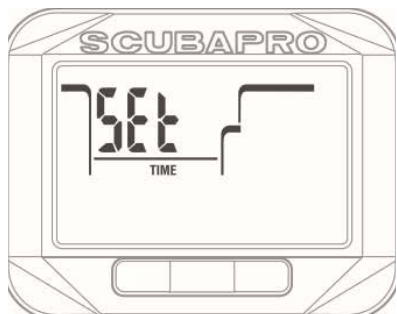

- After replacing the battery, you must set the date and time.
- **There are two O-rings at Square battery compartment.**
- Both O-rings must be replaced each time when Square is opened.



## 5.4 Warranty

Square has a two-year warranty covering defects in workmanship and functioning. The warranty only covers dive computers which have been bought from an authorized SCUBAPRO dealer. Repairs or replacements during the warranty period do not extend the warranty period itself.

Excluded from warranty coverage are faults or defects due to:

- excessive wear and tear
- exterior influences, e.g. transport damage, damage due to bumping and hitting, influences of weather or other natural phenomena
- servicing, repairs or the opening of the dive computer by anybody not authorized to do so by the manufacturer
- pressure tests which do not take place in water
- diving accidents
- improper placement of the battery cap.

For European Union markets, the warranty of this product is governed by European legislation in force in each EU member state. All warranty claims must be returned with dated proof-of-purchase to an Authorized SCUBAPRO Dealer. Visit [www.scubapro.com](http://www.scubapro.com) for the dealer nearest you.

Your dive instrument is manufactured with high-quality components that can be recycled and reused.

Nevertheless these components, if not properly managed in accordance with the regulations on waste electrical and electronic equipment, are likely to cause harm to the environment and/or to human health.

Customers living in the European Union can contribute to protecting the environment and health by returning old products to an appropriate collection point in their neighbourhood in accordance with EU Directive 2012/19/UE.

Collection points are in particular provided by some distributors of the products and local authorities.

Products marked with the recycling symbol on the left must not be disposed of in normal household waste.





## 6. GLOSSARY

AVG:	Average depth, calculated from the beginning of the dive or from the time of reset.
CNS O <sub>2</sub> :	Central Nervous System oxygen toxicity.
DESAT:	Desaturation time. The time needed for the body to completely eliminate any nitrogen taken up during diving.
Dive time:	The time spent below a depth of 0.8m/3ft.
Gas 1, gas d	Refers to the main gas (1) and the decompression gas (d) when using the multi gas option of the ZH-L8 ADT MB PMG algorithm.
Local time:	the time in the local time zone.
Max depth:	Maximum depth attained during the dive.
MB:	Microbubble. Microbubbles are tiny bubbles that can build up in a diver's body during and after a dive.
MB level:	One of the six steps, or levels, in SCUBAPRO's customizable algorithm.
MOD:	Maximum Operating Depth. This is the depth at which the partial pressure of oxygen (ppO <sub>2</sub> ) reaches the maximum allowed level (ppO <sub>2</sub> max). Diving deeper than the MOD will expose the diver to unsafe ppO <sub>2</sub> levels.
Multi gas:	Refers to a dive in which more than one breathing gas is used (air and/or Nitrox).
Nitrox:	A breathing mix made of oxygen and nitrogen, with the oxygen concentration being 22% or higher. In this manual, air is considered as a particular type of Nitrox.
NO FLY:	Minimum amount of time the diver should wait before taking a plane.
No-stop time:	This is the time that a diver can stay at the current depth and still make a direct ascent to the surface without having to perform decompression stops.
O <sub>2</sub> :	Oxygen.
%O <sub>2</sub> :	Oxygen concentration used by the computer in all calculations.
PDIS:	Profile Dependent Intermediate Stop is an additional deep stop which is suggested by Square at depth where 3rd, 4th or 5th compartment starts off gassing.
PMG	Predictive Multi Gas, refers to the algorithm capable of including up to two different Nitrox mixes in its decompression calculations.
ppO <sub>2</sub> :	Partial pressure of oxygen. This is the pressure of the oxygen in the breathing mix. It is a function of depth and oxygen concentration. A ppO <sub>2</sub> higher than 1.6bar is considered dangerous.
ppO <sub>2</sub> max:	The maximum allowed value for ppO <sub>2</sub> . Together with the oxygen concentration it defines the MOD.
Press:	The act of pressing and releasing one of the buttons.
Press and hold:	The act of pressing and holding one of the buttons for 1 second before releasing it.
INT.:	Surface interval, the time from the moment the dive is closed.

- SOS mode: The result of having completed a dive without respecting all mandatory decompression obligations.
- Stopwatch: A stopwatch, for example to time certain legs of the dive.
- Switch depth: The depth at which the diver plans to switch to a higher oxygen concentration mix while using the multi gas option in the ZH-L8 ADT MB PMG algorithm.
- UTC: Universal Time Coordinated, refers to time zone changes when traveling.

## 7. INDEX

Active backlight	13, 17, 29, 40;
Warnings	34, 46;
All-silent mode	17;
Altimeter	9, 30;
Ascent rate	36;
Backlight	13, 17, 29, 40;
Battery	7, 13, 38, 47;
Bookmarks	29, 39;
Buttons	6, 28;
Clock settings	15
CNS O <sub>2</sub>	32, 35, 37, 49;
Date	8, 16;
Desaturation	49
Desaturation reset	21, 31;
Dive planner	9;
Diving at altitude	29;
Flying after diving	30;
Gauge mode	42;
Heart rate monitor	23, 26, 44;
Logbook	8, 10, 45;
Maintenance	47;
MB levels	40, 49;
Microbubbles	40, 49;
MOD	10, 37, 49;
Mountain lakes	31;
No-dive warning	31;
Nitrox	21, 32, 49;
Nitrox reset	21;
No-fly time	8, 29, 42, 49;
Oxygen concentration	32;
Oxygen partial pressure	32;
PC interface	45;
PMG	33, 49;
ppO <sub>2</sub> max	49;
Safety stop timer	40;
LogTRAK	45;
SOS mode	31, 50;
Stopwatch	42, 50;
Surface interval	8, 26, 49;
Technical information	47;
Time of day	8, 43;
Time zone	49;
Units	17;
UTC	16, 50;
Water contact	18, 45, 47;
Water type	24;

