



**Aladin TEC 3G**  
**User manual**

**deep down you want the best**

[scubapro.com](http://scubapro.com)



## SAFETY CONSIDERATIONS

You must carefully read and understand this entire manual before using your Scubapro Aladin TEC 3G.

### WARNING

**Diving has many inherent risks. Even if you follow the instructions of this manual in a careful manner, it is still possible that you may be seriously injured or die from decompression sickness, oxygen toxicity or some other inherent risk of scuba with Nitrox or compressed air. Unless you are fully aware of these risks and are willing to personally accept and assume responsibility for those risks, do not use Aladin TEC 3G.**

### ***Guidelines for the use of Aladin TEC 3G***

The following guidelines for using Aladin TEC 3G are derived from the latest medical research and the recommendations of the American Academy of Underwater Sciences for diving with diving computers. Following these guidelines will greatly increase your safety while diving, but cannot guarantee that decompression sickness or oxygen toxicity will not occur.

- Aladin TEC 3G is designed for dives with compressed air (21% O<sub>2</sub>) and Nitrox (22 to 100% O<sub>2</sub>) only. Do not use Aladin TEC 3G for dives made with other mixed gases.
- It is absolutely necessary to check the set mixture before each dive and to compare it to the gas mixture currently used. Always remember: setting an incorrect mixture carries an inherent risk of decompression sickness and/or oxygen toxicity! Maximum deviation from the measured mixture must not exceed 1%O<sub>2</sub>. An incorrect gas mixture can be lethal!
- Only use Aladin TEC 3G for diving with an independent breathing apparatus. Aladin TEC 3G is not designed for long term exposures with Nitrox.
- Always observe the visual and audible alarm signals. Avoid situations of increased risk which are marked with a warning sign in this operating manual.
- Aladin TEC 3G has a ppO<sub>2</sub> warning. The default limit is set at 1.4bar ppO<sub>2</sub> max. It can be changed between 1.2 and 1.6bar.
- Frequently check the “oxygen clock” (CNSO<sub>2</sub>). Ascend and finish the dive if the CNS O<sub>2</sub> exceeds 75%.
- Never dive deeper than the Maximum Operating Depth (MOD) pertinent to the gas mixture in use.
- Always check the diving limits considering the oxygen content and standard sports diving procedures (decompression sickness, oxygen toxicity).
- In accordance with the recommended maximum diving limit of all instructional agencies, do not dive deeper than 40 metres/130 feet.
- The danger of nitrogen narcosis has to be taken into consideration. Aladin TEC 3G gives no warning about this.
- On all dives, with or without dive computer, make a safety stop for at least 3 minutes at 5 metres (15 feet).
- All divers using dive computers to plan dives and indicate or determine decompression status must use their own computer, which they take with them on all dives.
- If Aladin TEC 3G fails at any time during the dive, the dive must be terminated, and appropriate surfacing procedures (including a slow ascent and a 3 to 5 minute safety stop at 5 metres /15 feet) should be initiated immediately.
- Comply with the ascent rate and carry out any decompression stop required. If the computer should fail for any reason, you must ascend at a rate of 10m (30ft) per minute or less.
- On any given dive, both divers in a buddy pair must follow the most conservative dive computer for that particular dive.
- Never dive without a buddy. Aladin TEC 3G does not substitute for a dive buddy.
- Only make dives that are appropriate to your level of dive training. Aladin TEC 3G does not increase your knowledge of diving.
- Always dive with back-up instruments. Make sure that you always use back-up instrumentation including a depth gauge, submersible pressure gauge, digital bottom timer or dive watch, and have access to decompression tables whenever diving with a dive computer.

- Avoid repeated ascents and descents (yo yo diving).
- Avoid repeated heavy workload while at depth.
- Plan the dives to be shorter if they are made in cold water.
- After finishing the decompression or at the end of a no-stop dive, the final stage of the ascent should be as slow as possible.
- You MUST be familiar with all signs and symptoms of decompression sickness before using Aladin TEC 3G! Seek IMMEDIATE treatment for decompression sickness should any of these signs or symptoms occur after a dive! There is a direct correlation between the effectiveness of treatment and the delay between the onset of symptoms and the treatment for decompression sickness.
- Only dive with Nitrox after you have been thoroughly instructed by a recognized institution.

### Repetitive dives

- Do not start your next dive before your CNS O<sub>2</sub>% status has dropped below 40%.
- When diving with Nitrox, make sure your surface interval is long enough (just like diving with compressed air). Plan for a minimum surface interval of two hours. Oxygen, too, needs sufficient time to leave the body.
- Match gas mixture to the intended dive.
- Do not attempt a repetitive dive if the no-dive warning  is visible on the display.
- Plan a day without diving once a week.
- If you have to change computers, wait at least 48 hours before carrying out your next dive.
- Diving after a reset of the remaining saturation (reset, see page 90, or battery replacement, see page 99) may lead you into potentially hazardous situations which could result in death or serious injury. After a reset of the remaining saturation do not dive for at least 48 hours.

### Altitude and diving

- Do not dive at altitudes higher than 4000m (13000ft).
- After a dive do not rise to altitudes that Aladin TEC 3G prohibits via the flashing altitude range number (see page 38).



### Flying after diving

- After diving, wait at least 24 hours prior to flying.



Aladin TEC 3G dive instrument is compliant with the European Union directive 2014/30/EU.

### Standard EN 13319: 2000

Aladin TEC 3G dive instrument is also compliant with the European standard EN 13319: 2000 (EN 13319: 2000 – Depth gauges and combined depth and time measuring devices – Functional and safety requirements, tests methods).

# TABLE OF CONTENTS

Guidelines for the use of Aladin TEC 3G ..... 1

<b>1. Introduction</b> .....	<b>6</b>
<b>2. System and operation</b> .....	<b>10</b>
2.1 System description.....	10
2.2 Operation .....	10
2.2.1 Push buttons .....	10
2.2.2 Water contacts.....	11
2.2.3 Introduction to Scubapro LogTRAK .....	12
2.2.4 Switching on the display .....	15
2.2.5 How to navigate Aladin TEC 3G at the surface.....	16
2.2.6 Checking the desaturation time.....	16
2.2.7 Checking the surface interval .....	17
2.2.8 Displaying the date .....	17
2.2.9 Checking the battery condition.....	17
2.2.10 Active backlight .....	19
2.2.11 Switching off the display.....	19
2.2.12 Alarm clock.....	19
2.3 SOS mode .....	20
<b>3. Diving with Aladin TEC 3G</b> .....	<b>21</b>
3.1 Terminology / Symbols .....	21
3.1.1 General terminology / Display during no-stop phase .....	21
3.1.2 Display during decompression phase.....	22
3.1.3 Nitrox information (O <sub>2</sub> information).....	22
3.2 Attention messages and alarms.....	23
3.3 Preparation for the dive .....	24
3.3.1 Setting the gas mixture and ppO <sub>2</sub> max [0.6] .....	24
3.3.2 [L6] Setting the MB level.....	25
3.3.3 [U] Preparation for diving with 2 or 3 gas mixtures .....	25
3.3.4 Preparation for diving with CCR .....	25
3.3.5 Preparation for the dive and function check.....	26
3.4 Functions during the dive .....	26
3.4.1 Immersion .....	26
3.4.2 Setting bookmarks.....	26
3.4.3 Dive time .....	27
3.4.4 Current depth / O <sub>2</sub> % mix.....	27
3.4.5 Max depth / Temperature.....	28
3.4.6 Ascent rate .....	29
3.4.7 Partial pressure of oxygen (ppO <sub>2</sub> max) / Maximum Operating Depth (MOD) .....	30
3.4.8 Oxygen toxicity (CNS O <sub>2</sub> %).....	31
3.4.9 Nitrogen loading bar graph.....	32
3.4.10 Decompression information.....	32
3.4.11 Safety stop timer.....	35
3.5 Functions at the surface .....	35
3.5.1 End of a dive .....	35
3.5.2 Residual nitrogen bar graph .....	36
3.5.3 Desaturation time, No-fly time and No-dive warning.....	36

3.6	Diving in mountain lakes .....	38
3.6.1	Altimeter .....	38
3.6.2	Altitude ranges .....	38
3.6.3	Prohibited altitude .....	39
3.6.4	Decompression dives in mountain lakes .....	40
<b>4.</b>	<b>Gauge mode .....</b>	<b>41</b>
<b>5.</b>	<b>Apnea mode .....</b>	<b>44</b>
5.1	Switching the Apnea mode on and off .....	44
5.2	Diving in Apnea mode .....	45
<b>6.</b>	<b>Diving with microbubble (MB) levels .....</b>	<b>46</b>
6.1	Comparison of dives with MB level L0 and MB level L5 .....	47
6.2	Terminology .....	47
6.2.1	Display during MB no-stop phase .....	47
6.2.2	Display during level stop phase .....	48
6.3	Preparation for a dive with MB levels .....	49
6.3.1	Setting the MB level .....	49
6.4	Functions during the dive with MB levels .....	49
6.4.1	Level stop information .....	49
6.4.2	Total time of ascent .....	51
6.4.3	Decompression obligation .....	52
6.4.4	Level stop and deco stop .....	53
6.5	Complete a dive with MB levels .....	53
<b>7.</b>	<b>PDIS (Profile Dependent Intermediate Stop) .....</b>	<b>54</b>
7.1	Introduction to PDIS (Profile-Dependent Intermediate Stop) .....	54
7.2	How does PDIS work? .....	55
7.3	Special considerations when diving with more than one gas mixture (Aladin TEC 3G) .....	56
7.4	Diving with PDIS .....	56
<b>8.</b>	<b>🚿 Diving with 2 or 3 gas mixtures .....</b>	<b>59</b>
<b>9.</b>	<b>CCR Diving .....</b>	<b>66</b>
9.1	Preparation for the CCR dive .....	66
9.1.1	Setting the ppO <sub>2</sub> and gas mixture .....	66
9.2	Functions during a CCR dive .....	69
<b>10.</b>	<b>Dive planner .....</b>	<b>76</b>
10.1	Planning a no-stop dive .....	77
10.2	Planning a decompression dive .....	78
10.3	Leaving the dive planner .....	79
<b>11.</b>	<b>Logbook .....</b>	<b>80</b>
11.1	Survey .....	80
11.2	Operation .....	80

<b>12. Settings</b> .....	<b>84</b>
12.1 Altitude adjustment.....	84
12.2 Menu “set 1” .....	84
12.3 Menu “set 2” .....	91
12.4 Menu “set 3” (Apnea).....	95
<b>13. Appendix</b> .....	<b>99</b>
13.1 Technical information.....	99
13.2 Maintenance .....	99
13.2.1 Replacing the battery.....	99
13.3 Warranty.....	102
13.4 Index.....	103

# 1. INTRODUCTION

Congratulations on purchasing Aladin TEC 3G and welcome to Scubapro. From now on you will enjoy the assistance of the most extraordinary dive computer - equipped with Scubapro's most innovative technology - while diving.

Aladin TEC 3G enables you to use up to 3 different gas mixtures during the same dive. However, for an easy reading this manual mainly refers to dives with a single gas mixture. Information for diving with more than 1 gas mixture is marked with  or has been summarized in special chapters.

We thank you for choosing Aladin TEC 3G and we hope you will enjoy safe dives in the future! Further information on Scubapro dive computers and other products by Scubapro can be found on our web page at [www.scubapro.com](http://www.scubapro.com).

## Safety considerations

*Dive computers provide divers with data; they, however, do not provide the knowledge how this data should be understood and applied. Dive computers cannot replace common sense! You must therefore carefully read and understand this entire manual before using your Aladin TEC 3G.*

## Important remarks concerning signal words and symbols

This operating manual makes use of the following icons to indicate especially important comments:

 **NOTE:**

*Information and tips which are important for optimal use of the functions of Aladin TEC 3G.*



**Danger!**



**WARNING**

**Indicates a potentially hazardous situation which, if not avoided, could result in death or serious injury.**

## The following symbols are used in the operating manual:



Flashing display



Page reference e.g. ->10



Valid only for dives with 2 / 3 gas mixtures

## Audible signals













Audible attention signal





Audible alarm signal







### Instructions for manual input







-   Press left push button
  -   Press and hold (1 second) left push button
- 
-   Press right push button
  -   Press and hold (1 second) right push button
-   Press and hold (1 second) both push buttons

### Alternate displays

By pushing   during the dive you can scroll through alternate displays.

How to get back to the first display:

- scrolling with   through the displays
- after 5 seconds: automatically if marked with 
- after 5 seconds: directly by pushing 1x  

E.g. Max depth   > Temperature   > Temperature, Time    > Max depth

-  Time out after 5 seconds without operation. Display switches back to original indication.

## Quick reference

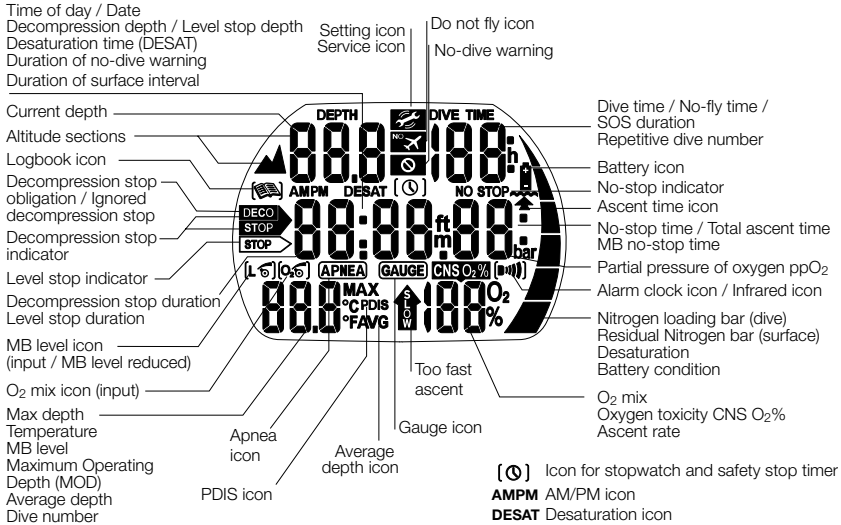

## Operating scheme

“->” means “more information at page”

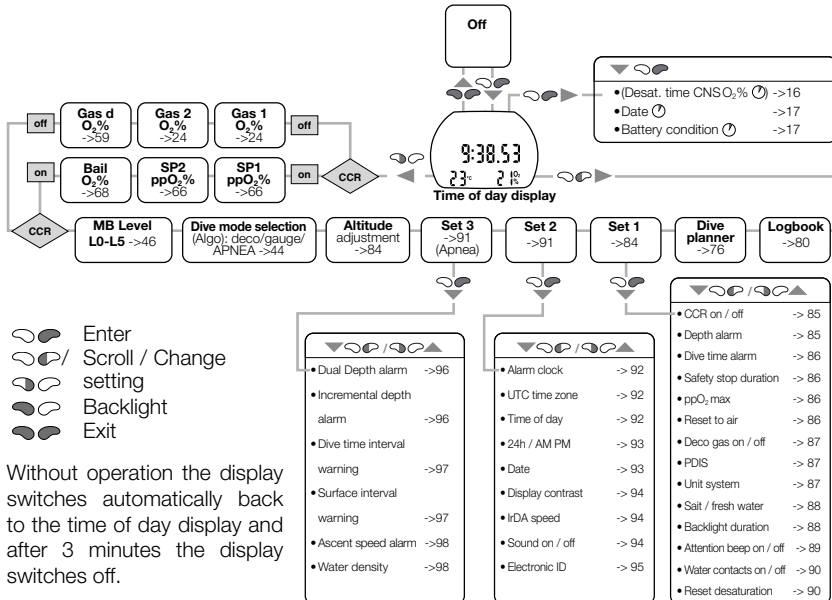

Without operation the display switches automatically back to the time of day display and after 3 minutes the display switches off.

See also page 16

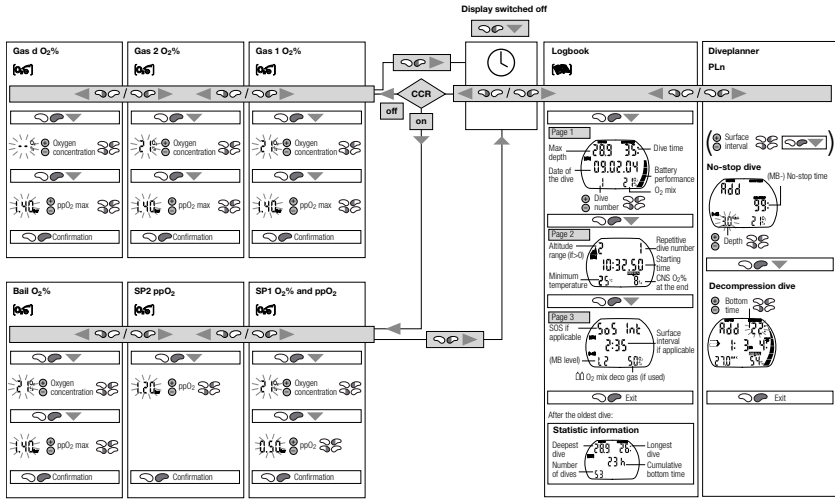

## 2. SYSTEM AND OPERATION

### 2.1 System description

Aladin TEC 3G displays all important dive and decompression data and has a memory which stores the full dive data. The data can be transmitted with an infrared interface (IrDA) and LogTRAK software to a Windows® personal computer.

LogTRAK software CD is included with the Aladin TEC 3G package.



— Infrared port

Aladin TEC 3G

LogTRAK

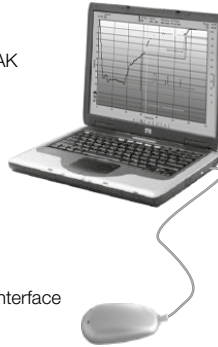

Infrared Interface  
(option)

### 2.2 Operation

**NOTE:** On page 8 and 16 you will find an operating schematic.

#### 2.2.1 Push buttons

Aladin TEC 3G can be operated with two push buttons (↵). Operation of the push buttons is divided into “press” (↵ / ⏏) and “press and hold (1 second)” (⏏ / ⏏).

**At the surface:**



Push buttons

Water contacts  
(one on front and one on back, inaccessible)

- Switch on Aladin TEC 3G (time of day display)
- Comparable to the ENTER or RETURN key of a keyboard
- Enter into the displayed sub menu
- Open the displayed setting
- Confirm or enter the displayed value or setting
- Scroll through a menu
- Once entered with into a sub menu or setting:
  - Increase () or decrease () the indicated value
  - Change the setting
- Operate the backlight
- Exit the current function or menu and switch to the time **of day display**
- Switch off Aladin TEC 3G

**Apnea mode:**

- Start dive manually



**Underwater dive mode (Algo):**

-  • Access alternate displays 
-  • Set bookmark
-  • Operate the backlight
-  • Activate the safety stop timer (dive mode only, in depths < 6.5m / 20ft)

**Gauge mode (stopwatch):**

-  • Restart

** Diving with 2 or 3 mixtures:**

-  • Initiate switch to gas d, gas 1 or gas 2
  -  Interrupt switching process
-  • Confirm switch to gas d, gas 1 or gas 2

**2.2.2 Water contacts**

On submerging in water the water contacts switch on Aladin TEC 3G automatically.

** WARNING**

If you have chosen the option "Water contacts off" ("set 1", ->84), Aladin TEC 3G will turn on with a delay of up to 1 minute into the dive. This will affect functioning of the computer. Make sure that the computer is on before starting the dive.

### 2.2.3 Introduction to Scubapro LogTRAK

LogTRAK is the software that allows Aladin TEC 3G to communicate with a Windows-based PC or Mac OS.

In order to take advantage of any of these features, you need to establish a communication between your PC and Aladin TEC 3G with a dongle.

To start the communication

1. Connect the dongle to your PC
2. Launch LogTRAK on your PC
3. Select the IrDa port where the dongle is connected  
Extras -> Options -> download



4. Select the port that is used for Aladin TEC 3G dongle.  
Place the Aladin TEC 3G on the dongle.

### Download dive profiles

From LogTRAK, by selecting Dive -> Download Dives you can transfer the Aladin TEC 3G Logbook to your PC or Mac.

There are three main views each showing a specific part of your dive logs:

**Profile** shows the graphical data of the dive.

**Details** about the dive, where you can edit, for example, the equipment and tank information.

**Location**, shows your dive site on the world map.

The selection tabs for views are on the left side of the main window.

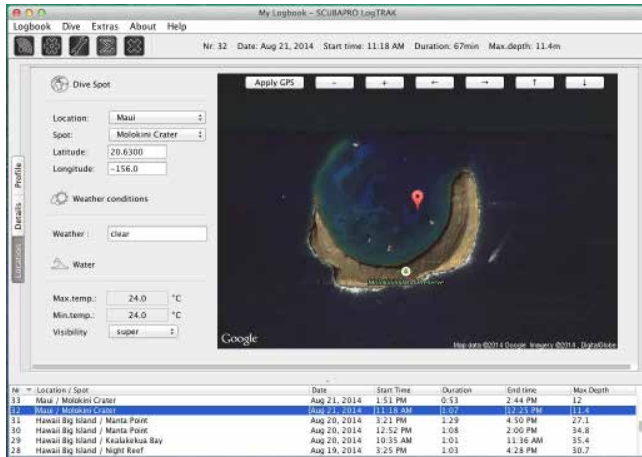
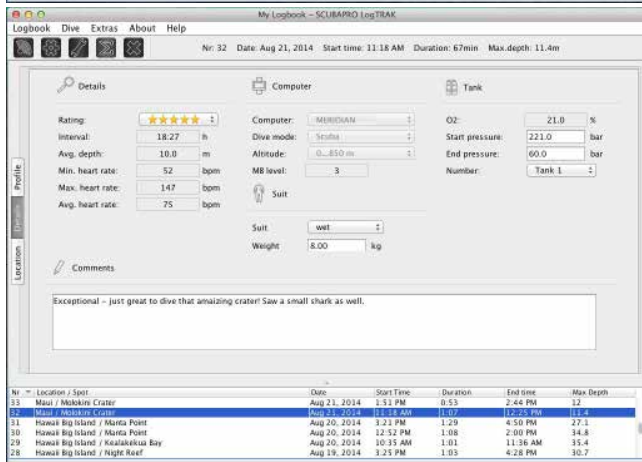

## Change warnings/settings of the Aladin TEC 3G and reading the computer information

By selecting Extras -> Read Dive Computer settings you can enable/disable warnings that cannot be enabled or disabled by using the menus on the Aladin TEC 3G unit.

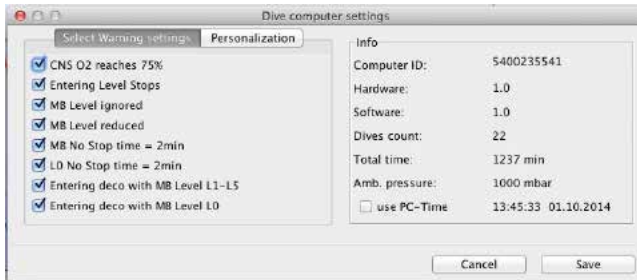

Read the chapter Warnings and alarms about the possible selections that you can modify on your Aladin TEC 3G.

You may also change the shown units between metric/imperial. Select Extras -> Options -> measurement units:

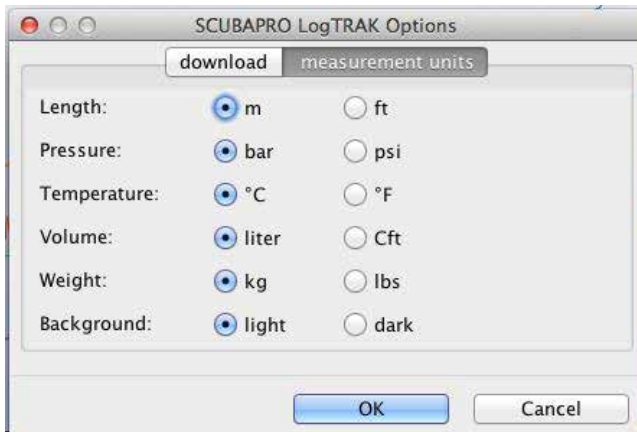



## 2.2.4 Switching on the display

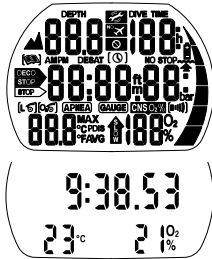

Time of day display

- automatically, on submerging in water\* or when adaptation to atmospheric pressure is necessary;
- manually, by pushing or . If switched on with all segments light up for 5 seconds.
- Afterwards the display shows the time of the day, the O<sub>2</sub> mix and the temperature.

**NOTE:** This display is called time of day display. Most navigation descriptions start from this display. At the surface Aladin TEC 3G returns automatically to this display.

If there is a remaining saturation from the last dive or from a change of altitude, Aladin TEC 3G also displays the "do not fly" time, the "do not fly" icon, the current altitude range and the prohibited altitude range (->38).

**NOTE:** When Aladin TEC 3G is in state of rest no information is displayed but the atmospheric pressure is continuously monitored. If a change in altitude range is detected, Aladin TEC 3G switches on for 3 minutes automatically ->38.

\* Only if the option "Water contacts on" ("set 1", ->90) is chosen. See warning ->11.

### 2.2.5 How to navigate Aladin TEC 3G at the surface

Starting from the **time of day display** you can enter into different menus.

"->" means "more information at page"

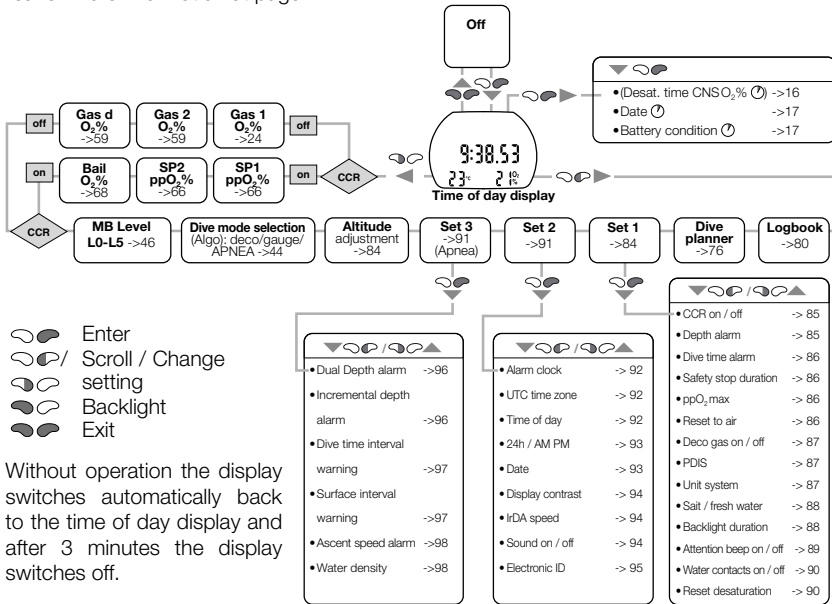

### 2.2.6 Checking the desaturation time

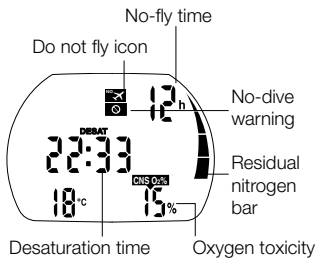

From the **time of day display** you can check the desaturation time\* by pushing . Desaturation time is determined either by oxygen toxicity, nitrogen saturation or the regression of microbubbles, depending on which requires the longer time.

The display switches back to the **time of day display** after 5 seconds without operation.

\* Only displayed if there is a remaining saturation due to the last dive or change of altitude.

## ⚠ WARNING

For the calculations of the desaturation and no-fly time it is assumed that the diver breathes air while on the surface.

### 2.2.7 Checking the surface interval

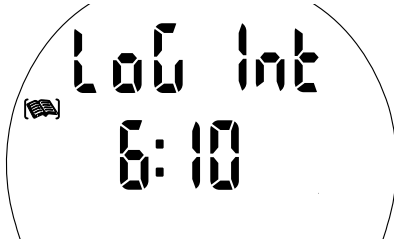

Surface interval

From the time of day display you can check the surface interval by pushing (logbook menu).

The surface interval is the time since the end of the last dive and is displayed as long as there is remaining saturation.



Date

### 2.2.8 Displaying the date

From the time of day display you can display the date by pushing 1x or 2x (depending on whether there is desaturation time left).

The display switches back to the time of day display after 5 seconds without operation.

### 2.2.9 Checking the battery condition

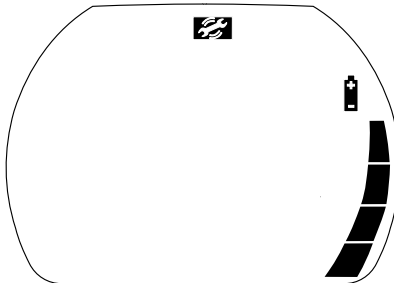

Battery condition / performance

From the time of day display you can check the battery condition by pushing 2x or 3 x (depending on whether there is desaturation time left).

Aladin TEC 3G displays the estimated remaining battery performance for 5 seconds as a bar graph. If the bar graph shows 3 segments the battery warning appears ->23 and the battery has to be replaced ->99.

## WARNING

- If the bar graph shows 2 segments, the battery symbol will blink, on the surface and in dive mode, to alert the diver of a dangerous situation: the battery may not have enough energy to finish a dive.
- Replace the battery when the steady battery symbol appears (3 segments)!

**NOTE:** The temperature influences the battery performance. In cold water it is lower than in warm water. If the battery shows 4 segments on the surface, it is possible for it to drop to 3 segments during the dive. If this is the case, the backlight will be temporarily disabled. See below.

Bar graph interpretation

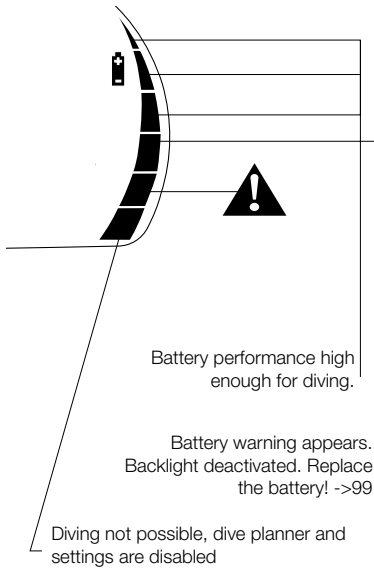

**⚠ WARNING**

**Flashing battery warning. Audible alarms and attention messages disabled! Backlight deactivated! Risk of computer malfunction. Do not let the battery reach this condition!**

Aladin TEC 3G marks dives started with 3 or less segments in the logbook with the battery symbol. Logbook information is not lost even when the battery is removed for a long time.

### 2.2.10 Active backlight

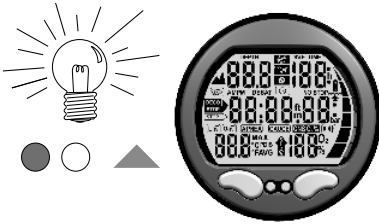

The display of Aladin TEC 3G can be illuminated both on the surface and underwater. The backlight can be activated by pushing . The light will turn off automatically. The default duration is 6 seconds. The duration can be changed in “set 1” (->84) or with LogTRAK between 2 and 12 seconds. It can also be set to “push on / push off”, in which case the light stays on until you turn it off by pressing again.

The backlight can only be activated if the computer display is on.

**NOTE:** Repeated activation of the backlight will reduce battery life.

**NOTE:** Keeping the backlight permanently on represents a severe strain on the battery. In warm waters (20 °C/68 °F and above), a new battery can sustain 20-40 1-hour dives with the backlight always on. In cold waters (4 °C/40 °F and below) the low battery warning may come on within the first dive. For temperatures between 4 °C/40 °F and 20 °C/68 °F the life of a new battery will be somewhere between 1 and 20 1-hour dives. Aladin TEC 3G monitors the battery level throughout every dive, and if the available energy drops below the warning threshold, Aladin TEC 3G will automatically disable the backlight to prevent a computer shut down.

### 2.2.11 Switching off the display

From the time of day display you can switch off Aladin TEC 3G by pushing .

On the surface Aladin TEC 3G switches off automatically after 3 minutes without operation.

### 2.2.12 Alarm clock

The alarm clock goes off only at the surface.

If the alarm clock is “on”, the time of day display shows .

When alarm is triggered: flashes and special attention beeps are played for 30 seconds or until the user presses a button.

Setting the alarm clock: ->92 (“set 2”)

## 2.3 SOS mode



Activation: automatic

If the diver remains above a depth of 0.8m (3ft) for more than three minutes without observing a prescribed decompression stop, the computer will automatically switch into SOS mode after the dive. Push  to see the "SOS" sign and the remaining length of the SOS mode. The dive will be entered in the logbook with "SOS".

The SOS mode will be unlocked after 24 hours.

While in SOS mode, the computer cannot be used for diving. The computer can however be used in gauge mode ->41. All segments in the nitrogen loading bar will flash throughout the dive.

Diving within 48 hours after the end of an SOS mode will result in shorter no stop times or longer decompression stops.

### WARNING

- **Serious injury or death may result if a diver does not seek immediate treatment should any signs or symptoms of decompression sickness occur after a dive.**
- **Do not dive to treat symptoms of decompression sickness!**
- **Diving in SOS mode is extremely dangerous and you must assume full responsibility for such behavior. Scubapro will assume no liability.**

A diving accident can be analyzed at any time in the logbook and downloaded to a PC by means of the infrared interface (IrDA) and LogTRAK software.



### 3.1.2 Display during decompression phase

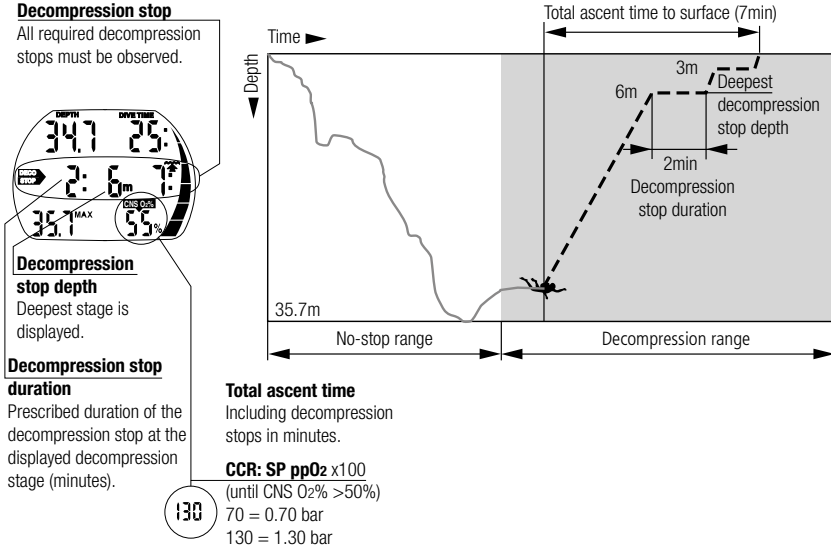

### 3.1.3 Nitrox information (O<sub>2</sub> information)

For dives with compressed air in normal recreational diving, nitrogen is the decisive gas for the decompression calculations. When diving with Nitrox, the risk of oxygen toxicity rises with the increase of the fraction of oxygen and the increase of depth and can limit dive time and the max depth. Aladin TEC 3G includes this in the calculations and displays the necessary information:

**O<sub>2</sub>% mix Fraction of oxygen:** The fraction of oxygen in the Nitrox mixture can be set between 21% (normal compressed air) and 100% in 1% increments. Your selected mix will be the basis for all calculations.

**ppO<sub>2</sub> max Maximum allowed partial pressure of oxygen:** the higher the fraction of oxygen in the mixture, the shallower the dive depth at which this value of the partial pressure of oxygen is reached. The depth at which ppO<sub>2</sub> max is reached is called Maximum Operating Depth (MOD).

When you enter the settings for the gas mixture, Aladin TEC 3G will display the ppO<sub>2</sub> max limit setting and the corresponding MOD. Aladin TEC 3G warns you audibly and visually once the depth is reached at which the ppO<sub>2</sub> reaches the maximum allowed value ->30.

**NOTE:**

- Default setting of ppO<sub>2</sub> max is 1.4bar.  
The value of ppO<sub>2</sub> max can be set by means of LogTRAK or with "set 1" between 1.2 and 1.6bar (->86). It can also be changed at the time of setting the gas mixture (->24).
- The CNS O<sub>2</sub>% value/alarm is not influenced by the selected ppO<sub>2</sub> max setting.

**CNS O<sub>2</sub>% Oxygen toxicity:** With the increased percentage of oxygen, the oxygen in the tissues, especially in the central nervous system (CNS), becomes important. If the partial pressure of oxygen rises above 0.5bar, the CNS O<sub>2</sub> value increases, if the partial pressure of oxygen is below 0.5bar, the CNS O<sub>2</sub> value decreases. The closer the CNS O<sub>2</sub> value is to 100%, the closer the limit where symptoms of oxygen toxicity can occur.



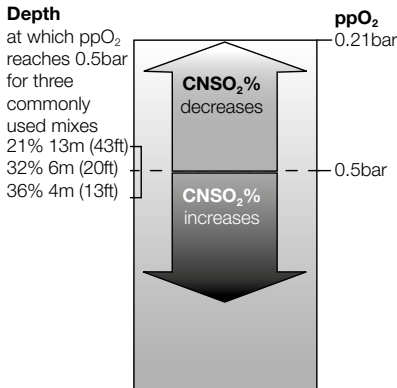

**⚠ WARNING**

Nitrox diving may only be attempted by experienced divers after proper training from an internationally recognized agency.

### 3.2 Attention messages and alarms

Aladin TEC 3G draws the diver's attention to certain situations and warns the diver of unsafe diving practices. Attention messages and alarms are visual and / or audible.

**🔊 NOTE:**

- The audible attention messages can be switched off in "set 1" ->84 or LogTRAK. With LogTRAK they can be switched off selectively.
- In addition, the sound can be turned off completely in "set 2" ->94.

**⚠ WARNING**

If you turn off the sound you will have no audible warnings. Without audible warnings you could inadvertently get into potentially hazardous situations which could result in death or serious injury.

**⚠ WARNING**

Serious injury or death may result from failing to immediately respond to alarms given by Aladin TEC 3G.

#### 3.2.1 Attention messages

Attention messages are communicated to the diver visually by symbols, letters or flashing figures. In addition, two short audible sequences can be heard (in an interval of 4 seconds) in two different frequencies under water.

«)) 4s «)) (can be switched off)

Attention messages come up in the following situations (more information can be found on the listed pages):

• Maximum Operating Depth / ppO <sub>2</sub> max is reached 30		Diving with MB levels (L1-L5):	
• Set max depth is reached	28	• MB no-stop time = 0	49
• Oxygen toxicity reaches 75%	31	• MB level stop ignored	50
• No-stop time less than 3 minutes	32	• MB level reduced	51
• Prohibited altitude (surface mode)	38	• Entering decompression when diving with MB level L1-L5	52
• Entering decompression (when diving with L0)	32		
• Half of set dive time is reached	27		
• Set dive time is reached	27		
•  Depth for tank switch has been reached	64		

### 3.2.2 Alarms

Alarms are given to the diver visually by flashing symbols, letters or figures. In addition, an audible sequence in one frequency can be heard during the whole duration of the alarm.

An alarm occurs in the following situations (more information can be found on the listed pages):

- Oxygen toxicity reaches 100% 31
- Ignored decompression 34
- Exceeding the prescribed ascent rate (Particular scale of beeps, ->29) 29
- Altitude alarm 38
- Low battery alarm (without audible alarm): the battery icon appears if the battery has to be replaced 99
- Apnea mode alarm 44

### 3.3 Preparation for the dive

You have to check the settings of Aladin TEC 3G especially before the first dive. All settings can be checked and changed directly at Aladin TEC 3G or via LogTRAK.

#### 3.3.1 Setting the gas mixture and ppO<sub>2</sub> max

#### WARNING

Before every dive and after changing the tank, make sure that the settings for the gas mixture correspond with the current mixture used. An incorrect setting causes Aladin TEC 3G to miscalculate this particular dive. If the fraction of oxygen is set too low this can lead to oxygen poisoning without warning. If the value is set too high decompression sickness may occur. Inaccuracies in the calculations are carried over to repetitive dives.

For dives with 2 or 3 gas mixtures please read page 59 for further reference.

For CCR dives please read page 66 for further reference.

To set the gas mixture, Aladin TEC 3G must be in user mode (time of day display).

or until

1. Push or until the GAS 1 O<sub>2</sub> menu appears.

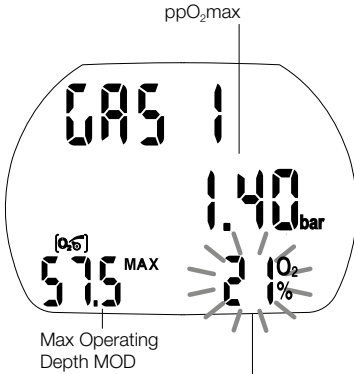

2. Confirm that you wish to change the oxygen fraction of gas 1 by pushing .

Change the O<sub>2</sub>% mix by (+) and (-)

3. Change the oxygen fraction in increments of 1% by pushing or . Aladin TEC 3G will display the current fraction of oxygen, the maximum partial pressure limit (ppO<sub>2</sub> max) and the MOD.
4. Confirm the selected percentage with .

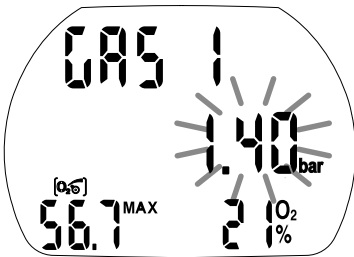

Change the ppO<sub>2</sub> max by (+) and (-)

5. By pushing or you can change the ppO<sub>2</sub> max for the chosen fraction of oxygen down to 1.0bar. Aladin TEC 3G will now display the corresponding MOD for the new ppO<sub>2</sub> max.
6. Confirm your ppO<sub>2</sub> max settings with .

NOTE:

- Without confirmation the display will disappear after 3 minutes and your entries will not be accepted.
- Automatic reset of the O<sub>2</sub>% mix to 21% can be set with "set 1" ->84 or LogTRAK between 1 and 48 hours or to "no reset" (default).

**3.3.2 Setting the MB level**

See chapter 6, ->46

**3.3.3 Preparation for diving with 2 or 3 gas mixtures**



See chapter 8, ->59

**3.3.4 Preparation for diving with CCR**

See page ->66

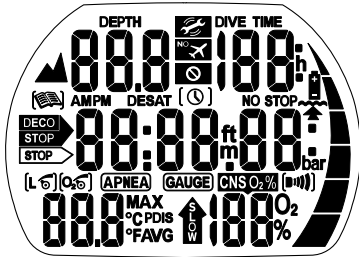
### 3.3.5 Preparation for the dive and function check



Switch on Aladin TEC 3G by pushing  and check the test display: Are all elements of the display activated? Do not use Aladin TEC 3G if the display does not show all elements. When switching on Aladin TEC 3G with , the test display will not appear.

#### WARNING

Check the battery capacity before each dive ->17.

## 3.4 Functions during the dive

### 3.4.1 Immersion



If the water contacts are deactivated (->90), switch on Aladin TEC 3G before immersion.

#### WARNING

If you have chosen the option “Water contacts off” (“set 1” or LogTRAK), Aladin TEC 3G will turn on with a delay of up to 1 minute into the dive. This will affect functioning of the computer. Make sure that the computer is on before starting the dive.

After immersion, starting at a depth of about 0.8m (3ft), all diving functions are monitored, i.e. depth and dive time displayed, max depth stored, saturation of tissues calculated, no-stop time or decompression prognosis determined, ascent rate controlled and displayed and the correctness of the decompression procedure supervised.

### 3.4.2 Setting bookmarks

During the dive you can create bookmarks in your dive profile by pressing . The logbook icon  appears for 4 seconds and an audible signal confirms the creation of the bookmark. These bookmarks will be graphically displayed in the dive profile of LogTRAK.

### 3.4.3 Dive time

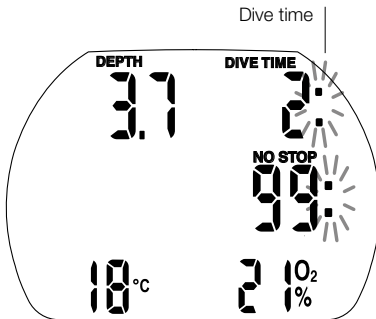

The whole time spent below a depth of 0.8m (3ft) is displayed as dive time in minutes. The time above 0.8m (3ft) is counted as dive time only if the diver descends again below 0.8m (3ft) within 5 minutes. While the dive time is running, the colons on the right of the figures are flashing in one second intervals. Maximum dive time displayed is 199 minutes.

**NOTE:** If a dive lasts longer than 199 minutes the dive time display starts again at 0 minutes.

#### WARNING

Half time alarm (turn around alarm) ->86

If half of the set maximum dive time has elapsed, an audible signal goes off and flashes for 1 minute.

#### WARNING

Set dive time has elapsed ->27, 86

An audible signal goes off and the dive time starts flashing.

### 3.4.4 Current depth / O<sub>2</sub>% mix

Current depth is given in 10cm increments in metric setting and 1ft increments in imperial setting.

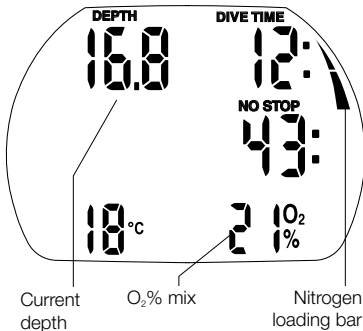

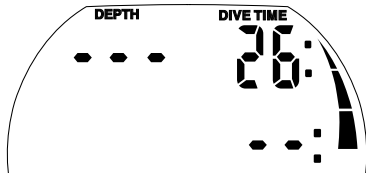

"---".

At a diving depth of less than 0.8m (3ft) the display shows

The O<sub>2</sub>% mix is displayed as long as CNS O<sub>2</sub>% = 0 and no ascent speed is indicated.

### 3.4.5 Max depth / Temperature

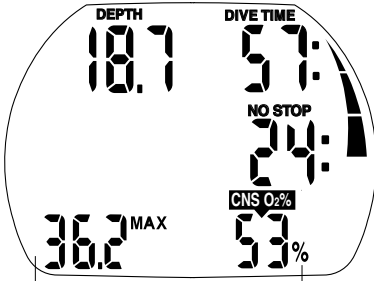

Max depth

CNS O<sub>2</sub>%

Max depth is only displayed if it exceeds the current depth by more than 1m (3ft) (maximum indicator function). If max depth is not displayed, Aladin TEC 3G shows the temperature.

- ☉ ☉ > Temperature, O<sub>2</sub> mix ☉
- ☉ ☉ > Temperature ☉, Time ☉, O<sub>2</sub> mix ☉
- ☉ ☉ > Max depth

### Set max depth reached

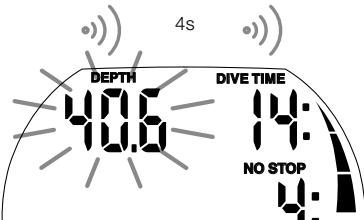

## ⚠ WARNING

If the max depth set with LogTRAK or “set 1” has been reached (default 40m/130ft) and the depth alarm is turned on, the depth display will flash.

Ascend until the depth stops flashing.

### 3.4.6 Ascent rate

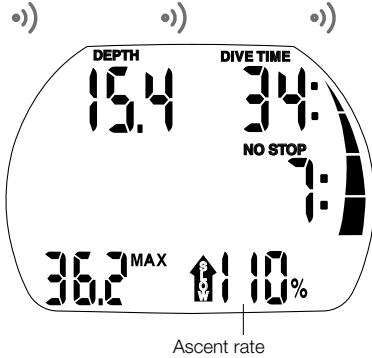

Ascent rate

Optimal ascent rate varies depending on depth between 7 and 20m/min (23 and 67ft/min). It is displayed as a percent of the reference variable ascent rate. If the ascent rate is greater than 100% of the set value, the black arrow "SLOW" appears. If the ascent rate exceeds 140%, the arrow starts flashing. Aladin TEC 3G provides an audible alarm if the ascent rate is 110% or greater. The intensity of the alarm increases in direct proportion to the degree that the prescribed ascent rate is exceeded.

#### WARNING

**The prescribed ascent rate must be observed at all times! Exceeding the prescribed ascent rate can lead to microbubbles in the arterial circulation which can lead to serious injury or death due to decompression sickness.**

- In case of an improper ascent Aladin TEC 3G may require a decompression stop even within the no-stop phase because of the danger of microbubble formation.
- The decompression duration necessary for the prevention of microbubbles can increase massively if the ascent rate is exceeded.
- From great depth a slow ascent may cause heightened saturation of tissues and an extension of both decompression duration and total ascent time.
- At shallow depth, a slow ascent may shorten the decompression duration.
- Display of the ascent rate has the priority over "CNSO<sub>2</sub>".

#### WARNING

Ascent rate	Visual alarm	Audible alarm
110%		•) •) •) •)
140%		•) •) •) •)
160%		•)•)•) •)•)•) •)•)•) •)•)•)
180%		•)•)•)•) •)•)•)•) •)•)•)•) •)•)•)•)

#### Reduce ascent rate

Excessive ascent rates for longer periods are entered in the logbook.

The following ascent rates correspond to the 100% value in Aladin TEC 3G.

depth (m)	speed (m/min)	depth (ft)	speed (ft/min)
<6	7	<20	23
<12	8	<40	26
<18	9	<60	29
<23	10	<75	33
<27	11	<88	36
<31	13	<101	43
<35	15	<115	49
<39	17	<128	56
<44	18	<144	59
<50	19	<164	62
>50	20	>164	66

**3.4.7 Partial pressure of oxygen (ppO<sub>2</sub> max) / Maximum Operating Depth (MOD)**

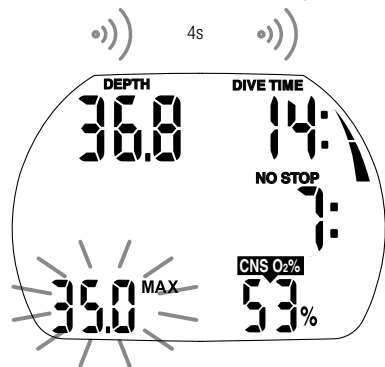

Max Operating Depth MOD

The maximum partial pressure of oxygen ppO<sub>2</sub> max (default 1.4bar) determines the Maximum Operating Depth (MOD). Diving deeper than the MOD will expose the diver to oxygen partial pressures higher than the set maximum level.

The ppO<sub>2</sub> max and consequently the MOD can be reduced manually (->24, setting the gas mixture, point 5).

In addition the maximum allowed ppO<sub>2</sub> can be set by means of LogTRAK or with "set 1" between 1.2 to 1.6 bar ->86.

**⚠ WARNING**

The MOD is a function of ppO<sub>2</sub> max and the mixture used. If during the dive the MOD is reached or exceeded Aladin TEC 3G sends an audible attention message and the MOD is displayed (flashing) in the lower left corner. Ascend to a depth shallower than the displayed MOD in order to diminish the danger of oxygen poisoning.

**⚠ WARNING**

The MOD should not be exceeded. Disregarding the warning can lead to oxygen poisoning.



3.4.8 Oxygen toxicity (CNS O<sub>2</sub>%)

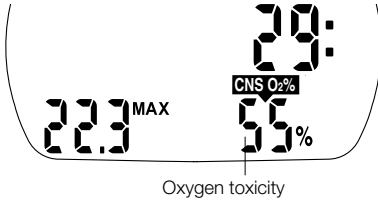

Aladin TEC 3G calculates oxygen toxicity based on depth, time and the gas mixture and displays it in the location of the ascent rate. The toxicity is expressed in 1% increments of a maximum tolerated value (O<sub>2</sub> clock).

The symbol "CNS O<sub>2</sub>" is displayed together with the percentage.

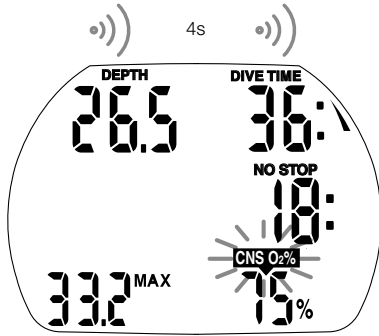

**⚠ WARNING**

An audible attention signal goes off if oxygen toxicity reaches 75%. The symbol "CNS O<sub>2</sub>" flashes. Ascend to shallower depth to decrease oxygen loading and consider terminating the dive.

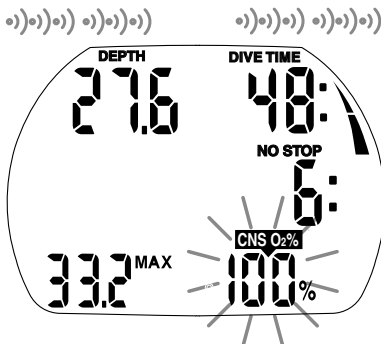

**⚠ WARNING**

When oxygen toxicity reaches 100%, an audible alarm goes off every 4 seconds. "CNS O<sub>2</sub>" and the percentage value flash. Danger of oxygen toxicity! Start procedure for terminating the dive.

**NOTE:**

- During an ascent and if the CNS O<sub>2</sub>% value does not increase anymore (due to a lower partial pressure of oxygen), the audible warning is suppressed.
- During the ascent, the display of the oxygen toxicity is replaced by the indication of the ascent rate. If the ascent is stopped, the display changes back to the indication of the CNS value.
- Aladin TEC 3G will display CNS O<sub>2</sub>% values exceeding 199% with 199%.
- Aladin TEC 3G displays CNS O<sub>2</sub>% values above 50%.

**3.4.9 Nitrogen loading bar graph**

The nitrogen loading bar gives a graphical representation of how close to decompression you are. As you absorb nitrogen during the dive, more and more segments of the bar will light up. Depending on your depth, the segments can light up more or less rapidly.

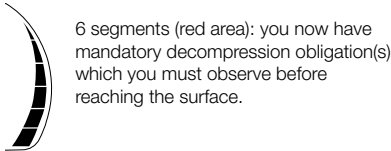
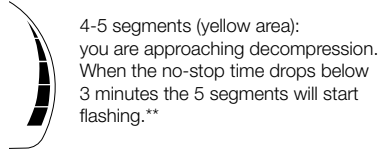
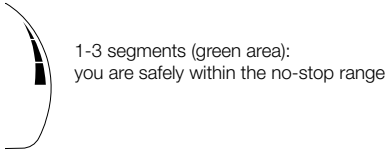

\*\* Depending on your profile, the no-stop time may drop below 3 minutes before the upper 5 segments are lit. In this case, only those segments that are lit will flash.

If you have entered decompression, the 6<sup>th</sup> segment will turn off as soon as you complete your last decompression obligation to indicate that you are no longer in decompression.

**3.4.10 Decompression information**

NO STOP and the no-stop time (minutes) are displayed if no decompression stops are necessary.

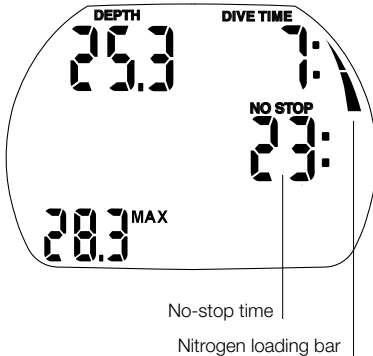

**NOTE:**

- No-stop display "99:" means remaining time of 99 minutes or more.
- No-stop time is influenced by the water temperature.

**WARNING**

If no-stop time drops below 3 minutes, an audible attention signal is activated, the no-stop value and the nitrogen loading bar begin to flash.

If no-stop time is less than 1 minute, the no-stop display shows the flashing value "0".

In order to prevent a decompression dive, ascend slowly until the no-stop time is 5 minutes or more.



**WARNING**

Decompression diving requires advanced training from a recognized agency. Do not attempt decompression diving without proper training from a recognized agency.

**Decompression values**

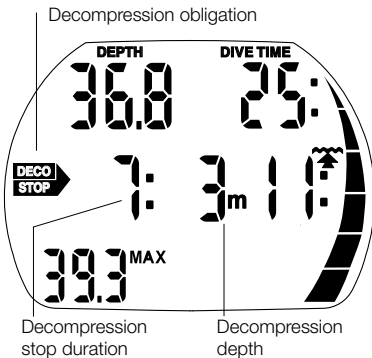



On entering the decompression phase, "NO STOP" disappears, the symbol appears and an attention beep goes off. The nitrogen loading bar stops flashing and the 6<sup>th</sup> segment lights up (red area). The deepest decompression stage in metres (feet) is displayed and the decompression stop duration of the displayed stage appears in minutes. The display "7: 3m (10ft)" means that a decompression stop of 7 minutes at a depth of 3m (10ft) has to be made.

When a decompression stop has been completed, the next (shallower) decompression stop is displayed. When all decompression stops have been completed, the symbol extinguishes, "NO STOP" and no-stop time reappear.

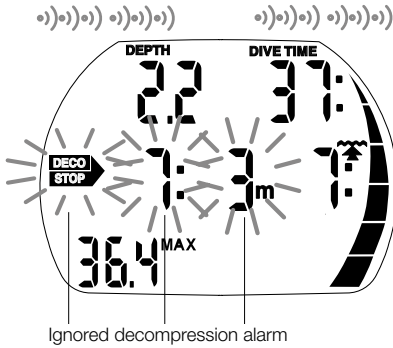
Deco stop depths deeper than 27m (90ft) are displayed as "-- : --".



**⚠ WARNING**

The decompression alarm is activated if the decompression stop is ignored. The arrow , the decompression stop duration and decompression stop depth begin to flash and an audible alarm goes off. Due to the formation of microbubbles, decompression can increase massively if a decompression stop is ignored. When the surface is reached during the decompression alarm, the arrow , the decompression stop duration and decompression stop depth continue flashing, in order to point to the risk of a decompression accident. The SOS mode is activated 3 minutes after the dive if corrective action is not taken (->20). If the total (cumulative) duration of the decompression alarm is longer than one minute, it is entered in the logbook. Descend to the prescribed decompression stop depth immediately!

**Total time of ascent**

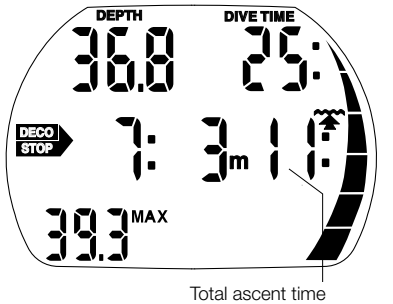

As soon as decompression stops are necessary Aladin TEC 3G shows the total time of ascent. This includes the ascent time from the current depth to the surface and all decompression stop obligations.

**👉 NOTE:**

- The total time of ascent is calculated on the basis of the prescribed ascent rate. Total time of ascent can be subject to change if the ascent rate is not ideal (100%).
- Ascent time greater than 99 minutes is displayed as “ -- ”.

**⚠ WARNING**

On all dives with Aladin TEC 3G, make a safety stop for at least three minutes at a depth of 5m (15ft).

### 3.4.11 Safety stop timer

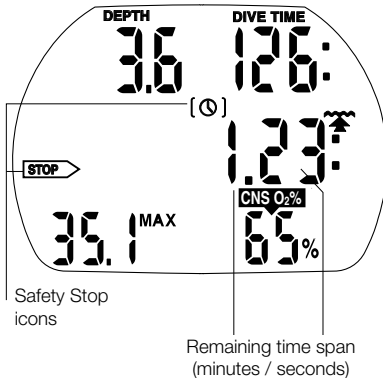

The safety stop timer displays the time span a diver should spend at the safety stop depth at the end of the dive. The timer starts automatically when depth is shallower than 6.5m and counts back from 3 minutes (default) to zero. It can be restarted manually any number of times. The duration of the timer can be set between 1 and 5 minutes.

The safety stop timer will be activated under the following conditions: depth <6.5m (21ft), no-stop display 99min, gauge mode is switched off, stop time is selected (1-5 min) at set 1 menu.

Activate the safety stop timer by pressing . The timer begins to count backwards and a bookmark will be created in the dive profile. If you press again, the timer will start again from the full value.

The safety stop timer will switch off automatically if the depth exceeds 6.5 m (21 ft) or the no-stop phase is shorter than 99 minutes.

## 3.5 Functions at the surface

### 3.5.1 End of a dive

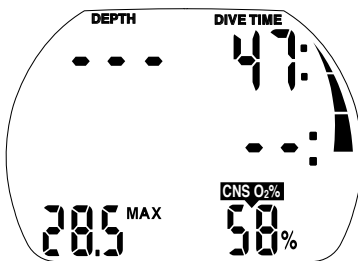

Depth less than 0.8m (3ft)

After reaching the surface (<0.8m/3ft) Aladin TEC 3G remains in dive mode for 5 minutes. The delay allows for surfacing for a short period for orientation.

After 5 minutes the dive is closed and it is entered into the logbook. The time of day is then displayed for 3 minutes, after which the computer turns off.

### WARNING

For the calculations of the desaturation and no-fly time it is assumed that the diver breathes air while on the surface.

### 3.5.2 Residual nitrogen bar graph

The segments in the residual nitrogen bar graph will gradually turn off as Aladin TEC 3G follows the offgassing of your tissues during your surface interval. There is a 1:1 equivalence in the meaning of the segments between diving and surface. Thus, on a repetitive dive the bar will resume from its status on the surface just prior to the dive. There are two exceptions however:

- the uppermost segment will stay lit until the desaturation time is completely extinguished. This is done to show that there is desaturation time left and that a dive started at this point will be logged as a repetitive dive. If the remaining desaturation time is very short, this segment could however at first disappear during the dive;
- during the 24 hours of an SOS-lock, all segments will stay on.

### 3.5.3 Desaturation time, No-fly time and No-dive warning

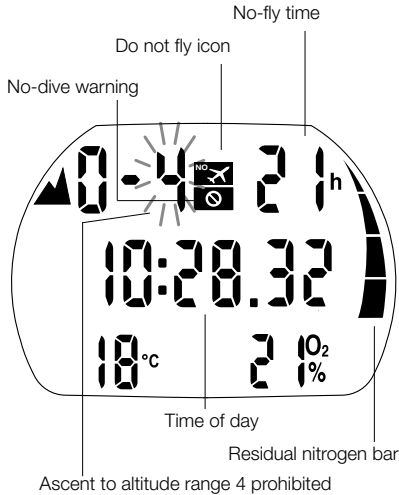

5 minutes after a dive Aladin TEC 3G shows the time of day, the “do not fly time”, the no-dive warning (if applicable), the current altitude range and the prohibited altitude range (->38).

**No-fly time** is the time in hours that should pass before a flight and is displayed and adjusted until the value becomes 0 hours.

**⚠ WARNING**

Flying while Aladin TEC 3G displays “do not fly” may lead to serious injury or death from decompression sickness.

**⚠ WARNING**

If the “no-dive” warning is visible during the surface interval, the diver should not undertake another dive.

To check the remaining **desaturation time** and oxygen toxicity press  .

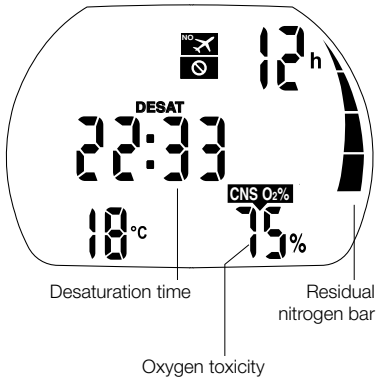

To check the **elapsed surface interval** press .

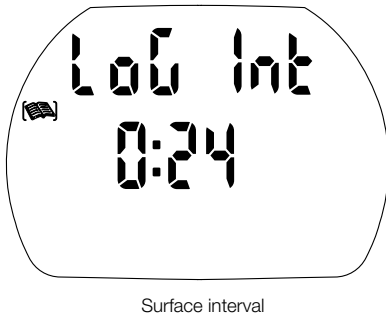

**Desaturation time** is determined either by oxygen toxicity, nitrogen saturation or the regression of microbubbles, depending on which requires the longer time.

### No-dive warning

If Aladin TEC 3G detects a situation of increased risk (due to the potential of microbubble accumulation from previous dives or a CNS O<sub>2</sub> level above 40%), the no-dive symbol will appear on the display. The duration of the no-dive warning is visible in the dive planner menu. Aladin TEC 3G recommends this as minimum surface interval in order to reduce the number of microbubbles and/or to reduce the CNS O<sub>2</sub> level below 40%.

*Note:* You should not undertake a dive as long as the no-dive warning message is displayed on the computer screen. If the warning is prompted by microbubble accumulation (as opposed to CNS O<sub>2</sub> over 40%) and you dive anyway, you will have shorter no-stop times or longer decompression times. Moreover, the duration of the no-dive warning at the end of the dive can increase considerably.

### 3.6 Diving in mountain lakes

#### 3.6.1 Altimeter

The altitude adjustment ->84 does not affect altitude ranges nor any calculations.

#### 3.6.2 Altitude ranges

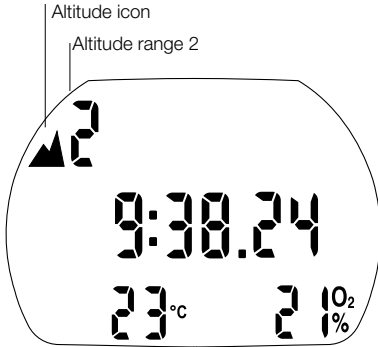

Aladin TEC 3G measures the atmospheric pressure every 60 seconds even while the display is switched off. If the computer detects a sufficient increase in altitude, it switches on automatically and indicates the new altitude range (1-4) and the desaturation time. Desaturation time indicated at this moment refers to adaptation time at this altitude. If the dive starts within this adaptation time, Aladin TEC 3G treats it as a repetitive dive, since the body is offgassing.

Altitude is divided into five ranges, which are influenced by barometric pressure. That is why the defined altitude ranges overlap on their fringes. If a mountain lake is reached, the altitude range is indicated at the surface (**time of day display**), in the logbook and in the dive planner by a stylized mountain and the current altitude range. Sea level to an altitude of approximately 1000m (3300ft) is not indicated. In the following diagram, you can see the approximate breakdown of the altitude ranges:

0 1 2 3 4

Altitude ranges

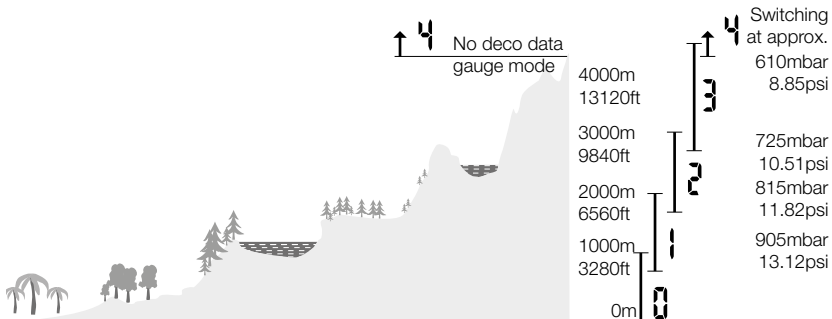



### 3.6.3 Prohibited altitude

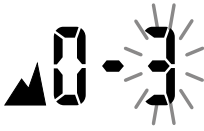

Ascent to altitude range 3 and 4 prohibited.  
Max allowed altitude: 2650m (8694ft).

**⚠ WARNING**

Aladin TEC 3G shows via flashing altitude segments while at the surface to which altitude the diver may not rise.

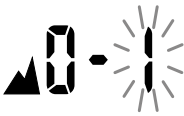

Max altitude:  
850m/2790ft

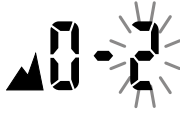

Max altitude:  
1650m/5413ft

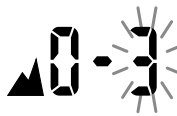

Max altitude:  
2650m/8694ft

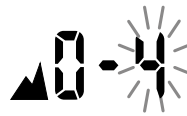

Max altitude:  
4000m/13120ft

The ascent prohibition can also be displayed together with an altitude range:



Example: You are at 1200m (3937ft) (altitude range 1) and you may ascend to range 2 only (2650m / 8694ft). You may not rise to the altitude range 3 or 4.

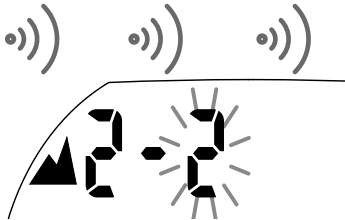

**⚠ WARNING**

If an ascent to a prohibited altitude is detected, an audible alarm goes off for 1 minute.  
Descend to a lower altitude.

### 3.6.4 Decompression dives in mountain lakes

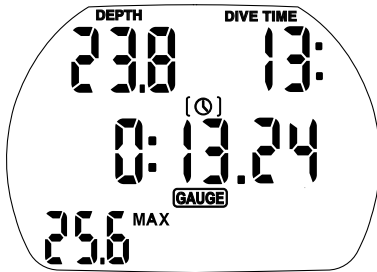

Dive at altitude range 4:  
no deco data (gauge mode)

In order to assure optimal decompression even at higher altitudes, the 3m (10ft) decompression stage is divided into a 4m (13ft) stage and a 2m (7ft) stage in altitude ranges 1, 2 and 3. The prescribed decompression stop depths are, in sequence, 2m / 4m / 6m / 9m... (7ft / 13ft / 20ft / 30ft...).



If atmospheric pressure is below 620mbar (8.99psi) (altitude higher than 4100m / 13450ft above sea level), Aladin TEC 3G switches automatically to gauge mode and no decompression data is calculated and displayed.

In addition, the dive planner is not available anymore.

## 4. GAUGE MODE

### WARNING

In gauge mode **ALL** audible and visual alarms and attention messages are turned off.

In gauge mode Aladin TEC 3G will display depth, dive time and max depth. By pressing  you can scroll from the max depth to the temperature, to the average depth, to the time of day and back to the max depth. By pressing  you can restart the stopwatch. This generates a bookmark. Gauge mode does not support the calculation of no-stop time or the supervision of decompression. Supervision of ppO<sub>2</sub> max and CNS O<sub>2</sub>% will also be switched off. Aladin TEC 3G will display no information about microbubble development. The settings for the gas mixture, MOD and microbubble level cannot be set and the dive planner cannot be selected.

#### Switching the gauge mode on and off

Gauge mode can be switched on and off at the surface, when there is no desaturation and no-dive in gauge mode has been made in the last 48 hours.





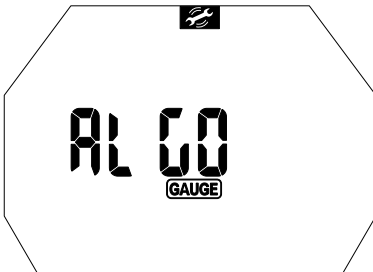

### WARNING

- Dives in gauge mode are performed at your own risk!
- After diving in gauge mode you must wait for at least 48 hours before using a decompression computer.

After diving in gauge mode, Aladin TEC 3G can not be used as dive computer for 48 hours.

Procedure:



1. From the time of day display push  or  until the "ALGO" is displayed.  
(If Aladin TEC 3G shows " --- " the gauge mode cannot be switched "on" or "off". Aladin TEC 3G shows " --- " for 48 hours after a dive in gauge mode and as long as there is remaining desaturation after a dive in computer mode.)
2. Confirm with  that you wish to activate or deactivate the gauge mode. "Deco", "Gauge" or "Apnea" starts flashing.
3. By pushing  or  the mode will scroll between: Gauge, Deco (SCUBA diving) or Apnea.  
Select: "Gauge".
4. Confirm your settings with .

Without confirmation the display will disappear after 3 minutes and your entries will not be accepted.

#### Diving in gauge mode

The following information is displayed in gauge mode:

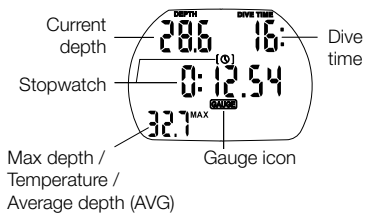

>Temperature

>Average depth (AVG)

>Temperature, Time

>Max depth

The **average depth** is continuously updated and represents the time averaged depth since the beginning of the dive.

You can **reset the average depth** at any time by pushing . This generates also a bookmark.

### Stopwatch



In gauge mode, after immersion, Aladin TEC 3G will automatically monitor the dive time and at the same time activate the stopwatch. The stopwatch will run for a maximum of 24 hours.

Resets time and starts stopwatch from zero.

Each start (restart) of the stopwatch creates a bookmark.

**After diving in gauge mode**

Remaining time during which Aladin TEC 3G cannot be used in computer mode

Aladin TEC 3G shows the remaining time span during which it cannot be used in computer mode. Once the waiting period is over, the gauge mode can be switched off manually ->41.

The no-fly time after diving in gauge mode is 48 hours.

Desaturation time will not be displayed.

## 5. APNEA MODE

### 5.1 Switching the Apnea mode on and off

Apnea mode can be switched on and off like gauge mode, when there is no desaturation and no apnea dives have been made in the last 48 hours.

#### WARNING





Apnea diving after SCUBA diving is not recommended. Check the latest recommendation from your Instructor or Diving organization.

#### WARNING

Aladin TEC 3G doesn't track nitrogen intake to your body at Apnea mode. Therefore no fly time after Apnea diving is set to 48 hours. Also SCUBA diving after Apnea is recommended only after sufficient surface time. Check the latest recommendation from your Instructor or Diving organization.

Procedure:



1. From the time of the **day display** push  or  until ALGO is displayed.
2. Confirm with  that you wish to activate or deactivate the Apnea mode. “Deco”, “Gauge” or “Apnea” starts flashing.
3. By pushing  scroll between modes and select the apnea mode.
4. Confirm your setting with .

#### WARNING

Scubapro highly recommends professional training in apnea or free diving techniques and physiology before conducting breath hold dives. No dive computer can replace the need for proper dive training. Insufficient or improper training may cause a diver to commit errors that can lead to serious injury or death.

#### WARNING

Deep repetitive Apnea dives are not recommended; leave enough recovery time between your Apnea dives.

#### WARNING

All breath hold dives include a risk of shallow water blackout, that is, a sudden loss of consciousness due to oxygen starvation.

Apnea diving is the most natural form of diving, known also as Free diving or Breath hold diving. Due to specific demands on Apnea diving, Aladin TEC 3G has now this mode integrated.

Apnea mode is comparable to gauge mode, it doesn't have a dive algorithm and all decisions are left to the diver. Therefore Scubapro recommends:



1. Never apnea dive alone.
2. Make only apnea dives which your education and physical condition allow.

In apnea diving fast descents and ascents are allowed. Therefore Aladin TEC 3G uses faster sampling of the depth for higher accuracy. Aladin TEC 3G updates display and maximum depth every 15 seconds, logbook is updated every second.

## 5.2 Diving in Apnea mode

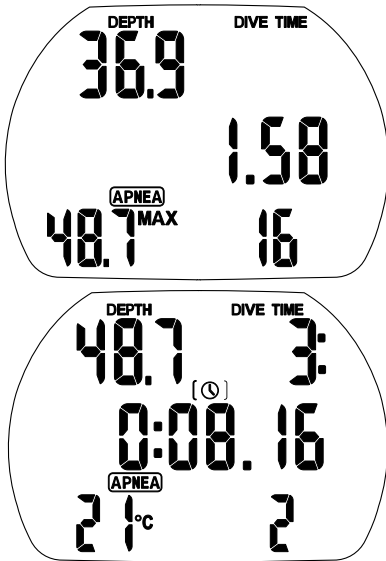
The following information is displayed in Apnea mode:



In Apnea mode the dive can be started manually by pressing . This function allows fast sampling to start straight from the surface. Automatic start of the apnea dive will happen from depth of 0.8m/3ft. Once activated the Apnea mode will run 15 minutes after surfacing. This allows you to start a repetitive apnea dive with precise data in the logbook. Surface mode can be stopped with long press .

Aladin TEC 3G Apnea mode has special alarms and functions tailored to Apnea diving and Apnea training. You can select multiple alarm functions at the same time. The alarm functions setup is explained in page ->95.

## 6. DIVING WITH MICROBUBBLE (MB) LEVELS

### NOTE:

*The following chapter deals with the characteristics of diving with microbubble (MB) levels. For general information about displays and features of diving with Aladin TEC 3G see chapter 3.*

**Microbubbles** are tiny bubbles that can build up inside a diver's body during any dive and normally dissipate naturally during an ascent and on the surface after a dive. Dives within no-stop time and observance of decompression stops do not prevent the formation of microbubbles in the venous blood circulation.

Dangerous microbubbles are those migrating into the arterial circulation. The reasons for the migration from the venous blood circulation to the arterial circulation can be a great many microbubbles collecting in the lungs. Scubapro has equipped Aladin TEC 3G dive computers with a new technology to protect from microbubbles.

The diver chooses – according to his/her needs – an MB level and influences through it the level of protection from microbubbles. Diving with MB levels requires additional ascent stops (level stops), the ascent is slowed down and the body gets more time to desaturate. This works contrary to the formation of the microbubbles and increases safety.

Aladin TEC 3G features **6 microbubble levels** (L0-L5). Level L0 corresponds to Scubapro's well-known decompression model ZH-L8 ADT and does not require level stops due to microbubble formation. Levels L1 to L5 offer additional protection from microbubble formation with level L5 offering the highest protection.

Similar to the display of information during decompression dives or dives within no-stop time, Aladin TEC 3G displays depth and duration of the first level stop as well as the total time of ascent as soon as the MB no-stop time has run out. As the MB no-stop time is shorter than the ordinary no-stop time a diver will be required to carry out a stop (level stop) sooner than a diver using level L0.

If a diver ignores a required level stop, Aladin TEC 3G will cascade to a lower MB level and the dive can not be completed with the initially chosen MB level. E.g. if a diver sets level L4 on Aladin TEC 3G prior to the dive and during the dive ignores the recommended stops Aladin TEC 3G will automatically adjust the setting to level L3 or lower.



## 6.1 Comparison of dives with MB level L0 and MB level L5

When two Aladin TEC 3G are used simultaneously, one unit is set for example to MB level L5, the other to L0, the no-stop time will be shortened and level stops will be required before the diver has the obligation of a decompression stop. These additional level stops help dissipate the microbubbles.

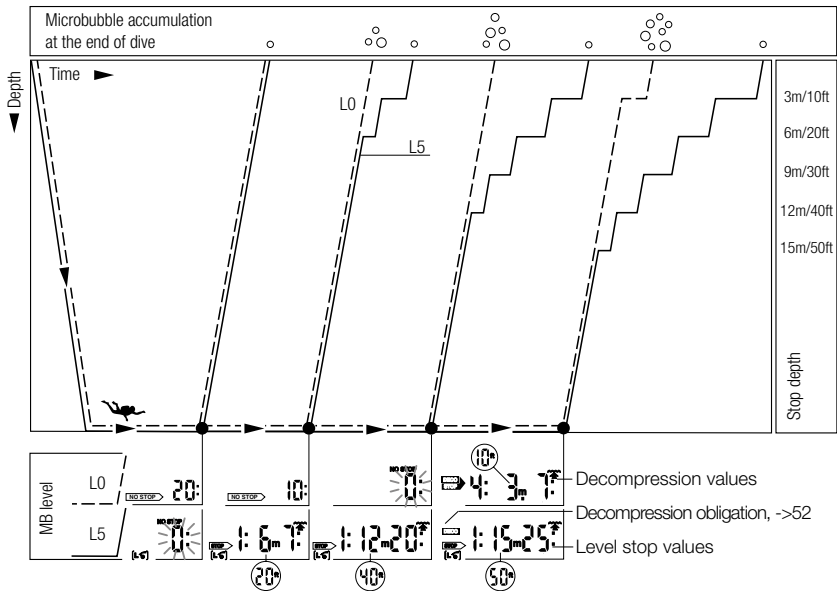

## 6.2 Terminology

This chapter will exclusively deal with terminology and display features used while diving with MB levels. All other features are described in chapter 3 (->21).

### 6.2.1 Display during MB no-stop phase

#### MB no-stop time

Remaining time at a respective depth allowing ascent without level stop.

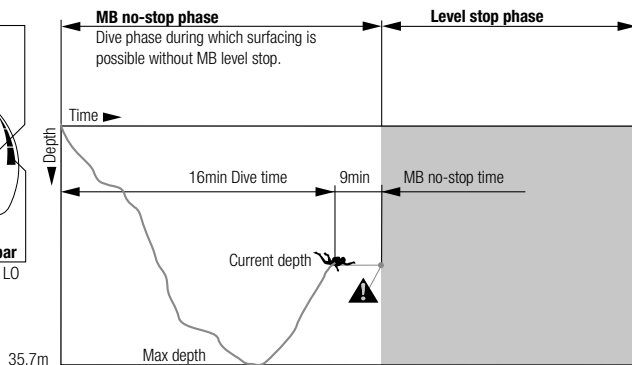
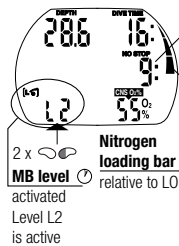

- ☉ (Max depth ☉☉ >) Temperature
- ☉☉ > MB level active ☉
- ☉☉ > No-stop time relative to L0 ☉
- ☉☉ > Temperature ☉ and time of day ☉
- ☉☉ > (Max depth)...

☞ NOTE:

Whereas the quantitative information relative to L0 can be seen by pressing the right button, qualitative information is always visible on the display in form of the nitrogen loading bar. In particular, when the L0 no-stop time is less than three minutes, the nitrogen bar will flash ->33. This will help you avoid entering inadvertently into decompression.

**6.2.2 Display during level stop phase**

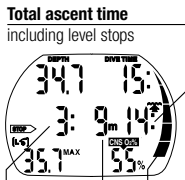

**Level stop depth**  
The deepest level stop is displayed.

**Level stop duration**  
The duration of a level stop at a given level stop depth is displayed.

**Nitrogen loading bar**  
relative to L0

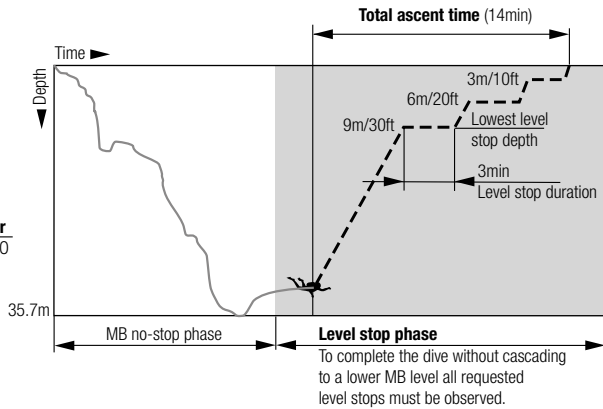

- ☉ (Max depth ☉☉ >) Temperature
- ☉☉ > MB level active ☉
- ☉☉ > No-stop time or deco information relative to L0 ☉
- ☉☉ > Temperature ☉ and time of day ☉
- ☉☉ > (Max depth)...

## 6.3 Preparation for a dive with MB levels

### 6.3.1 Setting the MB level

To change the MB level Aladin TEC 3G must be in user mode (**time of day display**).

or until **[L6]**

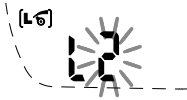

1. Push or until the symbol for MB levels **[L6]** appears.
2. Confirm that you wish to change the displayed MB level by pushing .
3. Change MB level by pushing or .
4. Confirm the selected MB level with .

Without confirmation the display will disappear after 3 minutes and your entries will not be accepted.

Aladin TEC 3G will display the **[L6]** symbol to confirm that an MB level beyond L0 (L1-L5) has been chosen. During the dive the MB level is shown by pressing 2x . If however a level stop is ignored, the new MB level is shown (->51).

**NOTE:**

*MB levels have an influence on the dive planner.*

## 6.4 Functions during the dive with MB levels

### 6.4.1 Level stop information

#### MB no-stop time

While diving with MB levels L1 to L5 Aladin TEC 3G will display the MB no-stop time instead of the ordinary no-stop time. Within the MB no-stop time no level stops are required.

“NO STOP” and the MB level symbol **[L6]** are visible. The remaining MB no-stop time is shown in minutes.

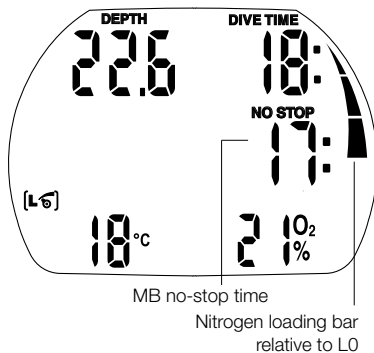

**NOTE:**

- Information and alarms for MB no-stop time and ordinary no-stop time are the same (->32).
- No-stop time relative to L0 is shown by pressing 3x (see )
- Regardless of the MB level, we generally recommend to perform a slow ascent during the last few metres / feet.

### Level stop

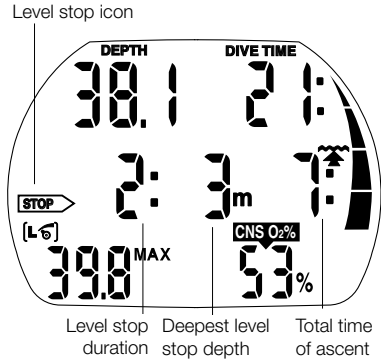

On entering the level stop phase, “NO STOP” disappears and the arrow **STOP** appears. The **STOP** arrow flashes for 8 seconds and an audible attention beep goes off. To complete the dive without cascading to a lower MB level, all requested level stops must be observed. The deepest level stop is displayed in metres (feet). The display “2: 3m ” (“2: 10ft”) means that a level stop of 2 minutes at a depth of 3 metres (10 feet) has to be observed. Deco information relative to L0 is shown on an alternate display (see ).

When a level stop has been finished, the next higher level stop – if present – is displayed. When all level stops have been observed, the arrow **STOP** extinguishes and “NO STOP” reappears. The indication of time shows the MB no-stop time again.

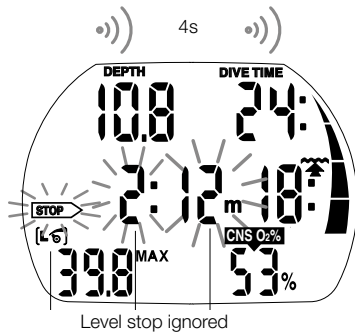

**⚠ WARNING**

The attention message “Level stop ignored” is activated if the requested level stop is not observed. An attention beep\* goes off and the arrow **STOP**, the depth and duration of the ignored level stop begin flashing. To complete the dive without being reduced to a lower MB level, you must descend to the prescribed depth immediately!

MB level reduced

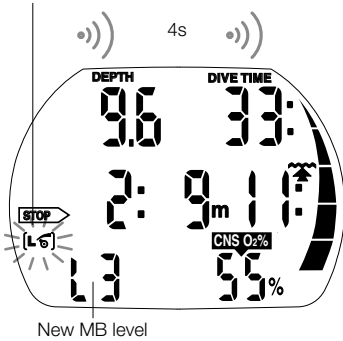

**⚠ WARNING**

The warning “MB level reduced” is activated if the diver ascends more than 1.5m (5ft) above the required level stop. Aladin TEC 3G reduces the MB level, an attention beep\* goes off and the new MB level is shown in the lower left corner. To complete the dive without being further reduced to an even lower MB level the new level stop must be observed.

**NOTE:**

\* Attention beeps can be suppressed with “set 1” (->89) or via LogTRAK.

**6.4.2 Total time of ascent**

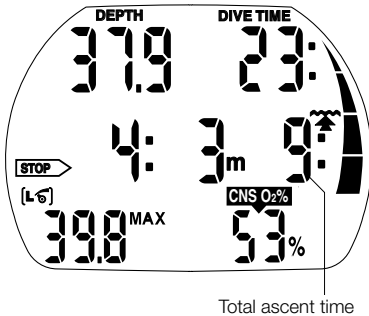

Aladin TEC 3G displays the level stop information and the total time of ascent. This includes the time of ascent as well as all level stops.

NOTE:

The total time of ascent is calculated on the basis of the prescribed ascent rate. Total time of ascent can be subject to change if the ascent rate is not ideal (100%).

### 6.4.3 Decompression obligation

Aladin TEC 3G calculates and displays level stops to reduce microbubble formation, but it also calculates the diver's decompression data.

## WARNING

Avoid decompression dives when diving with MB levels.

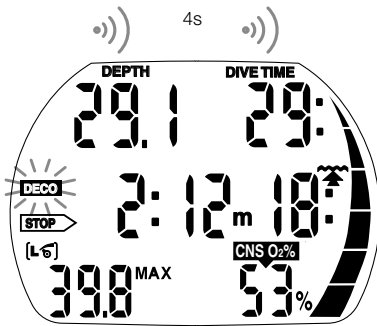

How to avoid decompression stops:

- Check ordinary no-stop time by pushing until L0 appears.
- Observe the nitrogen loading bar (it is relative to L0) ->32, ->47, ->48.
- If the nitrogen loading bar flashes (less than 3 minutes to deco): ascend slowly a few metres/feet.

## WARNING

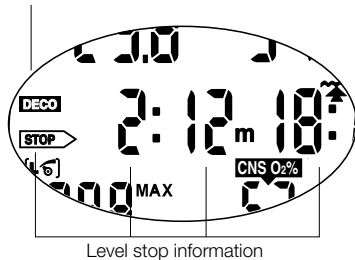

At the beginning of a decompression phase an attention beep goes off and the **DECO** symbol flashes for 8 seconds. In order to prevent a dive with long decompression stops it is recommended that you ascend a few metres/feet on seeing this message.

Decompression obligation



If decompression stops become obligatory, the **DECO** symbol will be displayed. The total ascent time will now also contain a decompression stop.

### 6.4.4 Level stop and deco stop

When the level stop depth equals the depth of the first obligatory decompression stop and if you are within 1.5m /5ft of the stop depth itself, Aladin TEC 3G shows  and  (level stop). The indicated duration refers to level stop duration.

Since level stops are more restrictive than decompression stops, when all decompression obligations have been observed the display changes from   to  only.

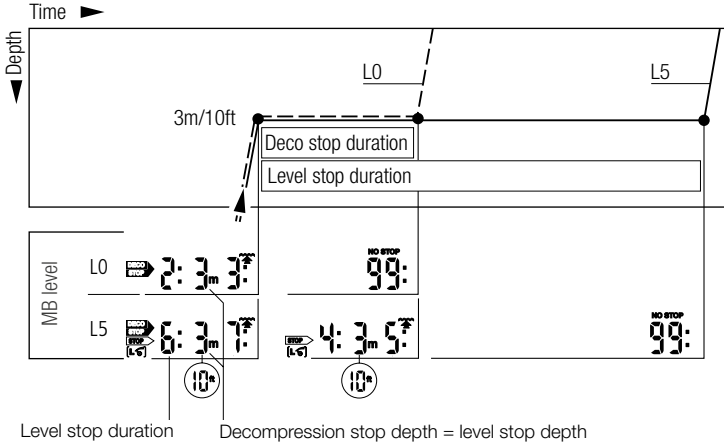

### 6.5 Complete a dive with MB levels

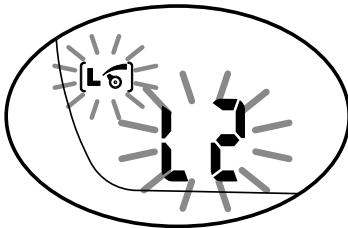

A dive with MB levels is completed the same way as a dive without MB levels (L0) (->35), save for the following exceptions:

If the MB level has been reduced during the dive, Aladin TEC 3G will display a flashing MB level symbol and the current MB level for five minutes after reaching the surface. The dive is then completed and Aladin TEC 3G changes to user mode with the MB level switching back to the original MB setting.

Repetitive dives and MB levels: If during a dive a level stop is being ignored and the diver starts another descent shortly afterwards, Aladin TEC 3G might immediately request level stops. To complete the dive with the initially set MB level all level stops must be observed.

## 7. PDIS (PROFILE DEPENDENT INTERMEDIATE STOP)

### 7.1 Introduction to PDIS (Profile-Dependent Intermediate Stop)

The main purpose of a dive computer is to track your nitrogen uptake and recommend a safe ascent procedure. Diving within the so called no-stop limits means that at the end of the dive you can ascend directly to the surface, albeit at a safe ascent rate, while for dives outside of the no-stop limit (so-called decompression dives), you must perform stops at certain depths below the surface and allow time for excess nitrogen to be expelled from your body before finishing the dive.

In both cases, it can be beneficial to stop for a few minutes at an intermediate depth between the maximum attained depth during the dive and the surface or, in case of a decompression dive, the first (deepest) decompression stop.

An intermediate stop of this kind is beneficial as soon as the ambient pressure at that depth is low enough to ensure that your body is predominantly offgassing nitrogen, even if under a very small pressure gradient. In such a situation, you can still cruise along the reef and enjoy the dive, while your body gets a chance to slowly release nitrogen.

In recent times, so called “deep” stops have been introduced in some dive computers and tables, defined as half the distance from the maximum reached depth and the surface (or the lowest decompression stop). Spending 2 or 15 minutes at 30m/100ft would result in the same deep stop of 15m/50ft. With PDIS, as the name suggests, Aladin TEC 3G interprets your dive profile and suggests an intermediate stop that is a function of your nitrogen uptake so far. The PDI stop will therefore change through the course of the dive to reflect the continuously changing situation in your body. Along the same lines, PDIS will account for the accumulated nitrogen from previous dives, hence PDIS is also repetitive-dive dependent. Conventional deep stops completely ignore these facts.

The following figure quantifies the extent of PDIS and illustrates its dependence on cumulative nitrogen uptake for two sample dive profiles. This figure also demonstrates the conceptual difference between PDIS and the rather rudimental “deep” stops.

Specifically, the figure compares two dive profiles to a maximum depth of 40m/132ft but otherwise very different. Profile 1 stays at 40m/132ft for 7 minutes, then ascends to 30m/100ft for 3 minutes, followed by 12 minutes at 20m/65ft. Profile 2 stays less than two minutes at 40m/132ft, then ascends to 21m/69ft and stays there for 33 minutes. Both dive profiles are no-stop dives to the limit of entering decompression. The solid line with triangles represents the PDIS depth as displayed on the computer screen during the course of the dive for profile 1, the dotted line with triangles represents the PDIS depth as displayed on the computer screen during the course of profile 2. One can see that the displayed PDIS depth increases as more nitrogen is accumulated in the body, but does so very differently in the two dives due to the different exposure in the two profiles. The PDI stop is carried out at 25 minutes for profile 1 and at 37 minutes for profile 2, followed by the safety stop at 5m/15ft.

The solid line with open circles on the other hand represents the depth that would be displayed by a computer following the conventional deep stop method, and it would be the same for the two dive profiles. Deep stops completely ignore any facts about the dives themselves aside for the max depth.



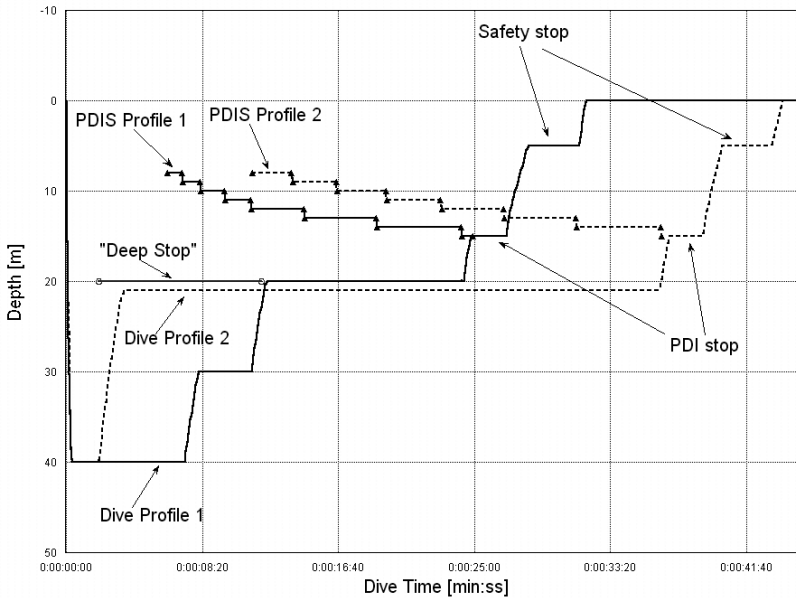

## 7.2 How does PDIS work?

The mathematical decompression model in Aladin TEC 3G, called ZH-L8 ADT MB PMG, tracks your decompression status by dividing your body into 8 so-called compartments and mathematically following the uptake and release of nitrogen in each with the appropriate laws of physics. The various compartments simulate parts of your body such as central nervous system, muscles, bones, skin and so on.

The depth of the PDI stop is calculated as that at which the leading compartment for the decompression calculation switches from ongassing to offgassing, and the diver is advised to perform a 2-minute stop **above** the displayed depth (this is the opposite of a decompression stop, where you are asked to remain just **beneath** the displayed depth). During this intermediate stop, the body is not taking up any more nitrogen in the leading compartment, but rather releasing nitrogen (though under a very small pressure gradient). This, combined with the relatively high ambient pressure, inhibits bubble growth.

It should be noted that the two fastest compartments, with 5 and 10 minutes half times respectively, are not considered for the determination of the PDI stop depth. This is due to the fact that these compartments are only “leading” for very short dives, for which an intermediate stop is not required at all.

**NOTE:**

**The PDI stop is not a mandatory stop and it is NOT a substitute for the 3-5 minute safety stop at 5m/15ft.**

### **WARNING**

**Even when performing a PDI stop, you still MUST perform a safety stop at 5m/15ft for 3 to 5 minutes. Performing a 3 to 5 minute stop at 5m/15ft at the end of ANY dive is still the best thing you can do for yourself!**

### 7.3 Special considerations when diving with more than one gas mixture (Aladin TEC 3G)

Switching to a higher oxygen concentration mix during the dive influences the PDI stop. This needs to be accounted for, in line with the predictive nature of multigas handling in ZH-L8 ADT MB PMG.

When diving with more than one gas mixture, Aladin TEC 3G displays the PDIS depth according to the following rules:

- if the PDI stop calculated for the bottom mix (gas 1) is deeper than the switch depth, than this calculated value is displayed;
- if the PDI stop calculated for gas 1 is shallower than the switch depth to gas d, then the displayed PDI stop is a function of gas d.

In case of a missed gas switch, Aladin TEC 3G reverts to the PDI stop for the actively breathed mix.

### 7.4 Diving with PDIS

 NOTE:

To use the PDIS feature, you must set **PDIS** to **ON** in the **PDIS** menu under **Set 1**. The default setting is **OFF**.

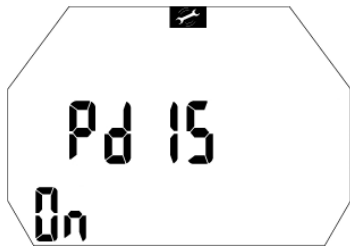

When the calculated PDI stop is deeper than 8m/25ft, Aladin TEC 3G shows it on the display and continues to do so until you reach the displayed depth during an ascent. The displayed value changes during the dive as Aladin TEC 3G tracks the uptake of nitrogen in the 8 compartments and updates the PDIS depth accordingly to reflect the optimum at all times.

The PDIS depth is shown in the lower left corner, with the label **PDIS**. During a no-stop dive, as soon as you reach that depth during an ascent, a 2-minute countdown will appear in place of the no-stop value with label **STOP**. In addition, the PDIS label will blink. You can have one of three situations:

- you have spent 2 minutes within 3m/10ft above the indicated depth. The countdown timer disappears and the **PDIS** value is replaced by the label **YES** as an indication that you have performed the PDI stop;
- you have descended by more than 0.5m/2ft below the PDIS. The countdown timer disappears and will reappear again, starting at 2 minutes, the next time you ascend to the PDIS depth;
- you have ascended by more than 3m/10ft above the PDIS. The **PDIS** value and countdown timer are replaced by the label **NO** to indicate the fact that you have not performed the PDI stop.

If Aladin TEC 3G is displaying a decompression obligation when you reach the PDIS depth during an ascent, all rules apply the same way, but the 2-minute countdown runs in the background and is not displayed on the screen. The PDIS label however will still be blinking to show you that you are in the PDIS range.

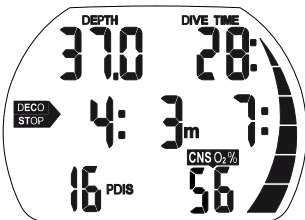
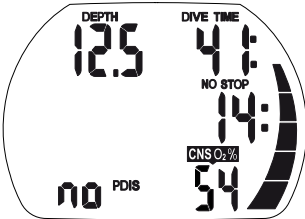
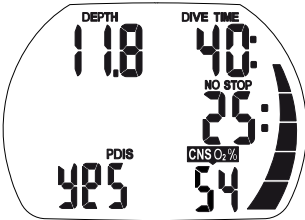
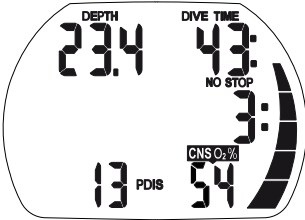

 NOTE:

*Aladin TEC 3G issues no warnings relating to a missed PDI stop.*

When diving with MB levels, PDIS follows the same rules as described above. MB levels, however, introduce stops earlier and deeper than the L0 base algorithm. As such, the PDIS display may be delayed and for certain dives it may not be displayed at all. This for instance would be the case for a shallow dive with air (21% oxygen) and MB level L5.

## 8. DIVING WITH 2 OR 3 GAS MIXTURES

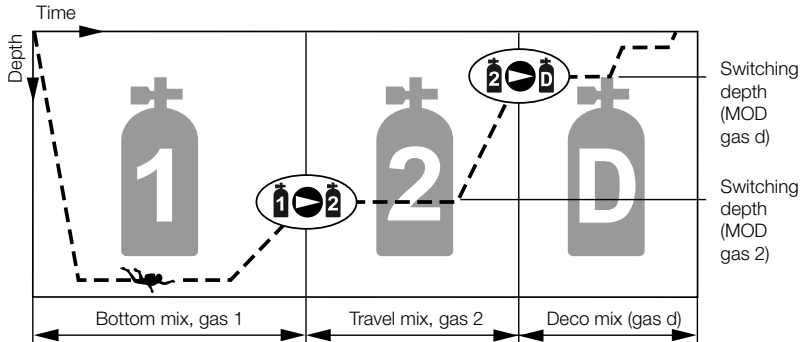

**NOTE:**

The following chapter deals with the characteristics of diving with 2 or 3 gases. In case of using 2 gas mixtures (gas 1 and d), just ignore the parts describing the gas 2.

Aladin TEC 3G enables you to use up to 3 different Nitrox mixtures during the same dive. Tank 1 contains the bottom mix (gas 1), tank 2 the travel mix and tank d contains the deco mix (gas d).

### Switching the deco gas option on and off

In order to enable two- or three gas diving you must turn on the deco gas option in the SET 1 menu ->87.

### Setting the gas mixture and the depth for changing the gas mixture

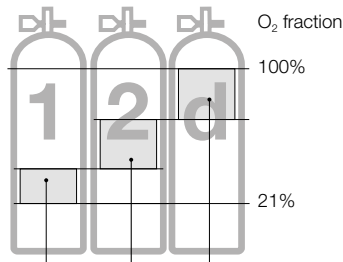

Range of O<sub>2</sub> fraction

During dives with 2 or 3 gas mixtures the bottom mix (gas 1) contains the lowest and gas d the highest fraction of oxygen.

Aladin TEC 3G will only accept settings corresponding with this order.

### **WARNING**

For gas mixtures having an oxygen percentage of 80% or greater the ppO<sub>2</sub> is fixed at 1.6bar and cannot be altered in any way.

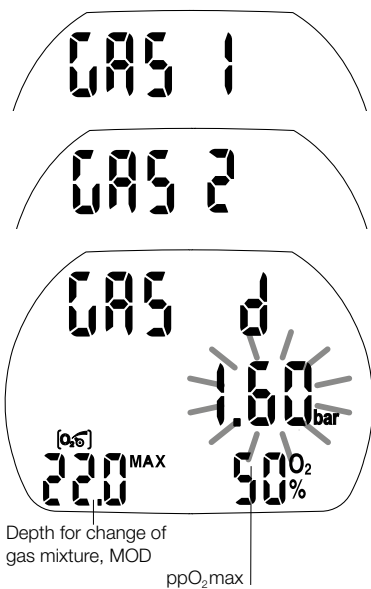

Procedure:

1. Enter the setting for the fraction of oxygen and the ppO<sub>2</sub> max (MOD) for gas 1 (bottom mix) according to the instructions on page 24 (points 1-6).
2. Repeat the process in the Gas 2 O<sub>2</sub> and the Gas d O<sub>2</sub> menu to set the oxygen fraction and ppO<sub>2</sub> max for gas 2 and gas d. Note that in this cases the resulting MODs correspond to the depths at which you plan to switch from gas 1 to gas 2 and from gas 2 to gas d during the ascent phase (switch depths).
3. If you set gas 2 and gas d to "--O<sub>2</sub>%", Aladin TEC 3G will compute the dive considering gas 1 only. Aladin TEC 3G will only accept a gas switch depths (MOD gas 2 / gas d) as input where the maximum partial pressure of oxygen (ppO<sub>2</sub> max), as pre-set manually (->24 point 5) or by means of LogTRAK, are not exceeded.

NOTE:

- During the ascent an audible and visual attention message will indicate that you have reached the depth which requires the change to gas 2 or gas d ->64.
- Without confirmation with the display will disappear after 3 minutes and your entries will not be accepted.
- If the deco gas option is turned on and the oxygen fraction of gas 2/ gas d is set to a value other than "--O<sub>2</sub>%", in surface mode and up to a depth of 0.8m Aladin TEC 3G will display "2G" or "3G" in the lower right corner of the display instead of a percentage value.



NOTE:

- The time to reset the O<sub>2</sub>% mix to air can be set with LogTRAK between 1 hour and 48 hours or to "no reset" (default).

After the reset, the oxygen fraction of gas 1 is set to 21%, the oxygen fractions of gas 2 and gas d are set to “– – O<sub>2</sub>%” (single gas dive).

### Switching between single-gas and two-gas diving

If gas 2 / gas d is not going to be used during the next dive you can either set it to “– – O<sub>2</sub>%” (->59, point 2) or you can turn off the deco gas option in SET 1. When you turn off the deco gas option in SET 1, the setting in the Gas 2 O<sub>2</sub> / Gas d O<sub>2</sub> menu remains but Aladin TEC 3G calculates the dive using gas 1 only.

If the deco gas option is turned off, the Gas2 O<sub>2</sub> / Gas d O<sub>2</sub> menu will display OFF in the lower left corner (instead of an MOD) and the ppO<sub>2</sub> setting will not appear.

### Functions during a dive with 2 or 3 gas mixtures

#### WARNING

**Diving with more than one gas mixture represents a much higher risk than diving with a single mixture, and mistakes by the diver may lead to serious injury or death.**

**During dives with several gas mixtures, always make sure you are breathing from the tank you intended to breath from. Mark all your tanks and regulators, so they can under no circumstances be mixed up! Before every dive and after changing a tank, make sure that each gas mixture is set to the correct value for the corresponding tank.**

### Predictive decompression prognosis

The calculation of decompression data is based on the assumption that the change(s) of gas mixture(s) will be performed at the previously selected switch depth(s) (MOD gas2 /gasd). If a diver ignores a required change or changes the mixture belatedly, Aladin TEC 3G will readjust the decompression calculation accordingly. In case of an ignored switch the dive computer will then base its calculations on the assumption that the diver will ascend to the surface with gas 1.



## Alternate displays during a dive with two gases

### NOTE:

*All displays time out after 5 seconds and the default display is shown again. (Only exception is the temperature, screen 2 below.)*

- ① The default display shows the predictive decompression prognosis, which assumes the diver will switch to the deco gas at the specified switch depth. In the bottom left corner the temperature is displayed unless the current depth is 1m/3ft shallower than the max depth, in which case the max depth is displayed.
- ② Upon pressing the right button, the temperature and the current O<sub>2</sub>% are shown in the lower row. O<sub>2</sub>% will time out after 5 sec while the temperature remains.
- ③ Upon pressing the right button, “GAS1”, “GAS2” or “GASd” appears in the middle row to indicate the currently active gas and the MOD appears in the bottom left corner. “GAS1”, “GAS2” or “GASd” will time out after 5 seconds unless the right button is pressed again.
- ④ Pressing the right button one more time shows O<sub>2</sub>% of the active gas in the bottom right corner and the decompression information in case the dive would be finished with the currently active gas (no switch to gas 2/deco gas). This is the calculation that Aladin TEC 3G would switch to in case, having reached the switch depth, the diver did not confirm the switch. The decompression information and the O<sub>2</sub>% blink.
- ⑤ If an MB level greater than L0 is active, pressing the right button one more time shows the predictive decompression information and in the bottom left corner the currently active MB level.
- ⑥ Pressing the right button again shows the predictive decompression information relative to L0 together with the L0 symbol at the bottom left.
- ⑦ One more right button push shows the decompression information relative to L0 if only gas 1 is used, with the decompression information and the O<sub>2</sub>% of gas 1 blinking.
- ⑧ Upon pressing the right button again, the time of day appears in the middle row.



**Gas 1 active, MB level L0**

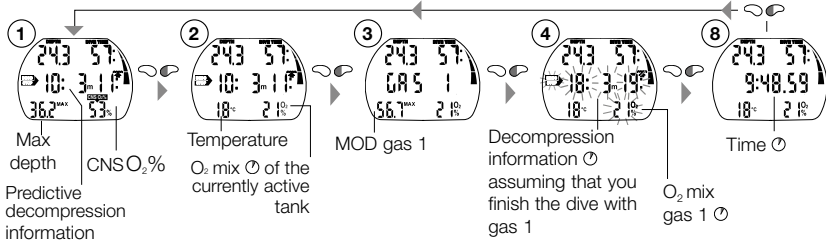

**Gas 2/d active, MB level L0**

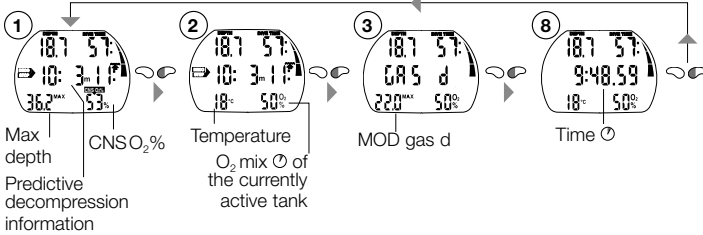

**Gas 1 active, MB level L1-L5**

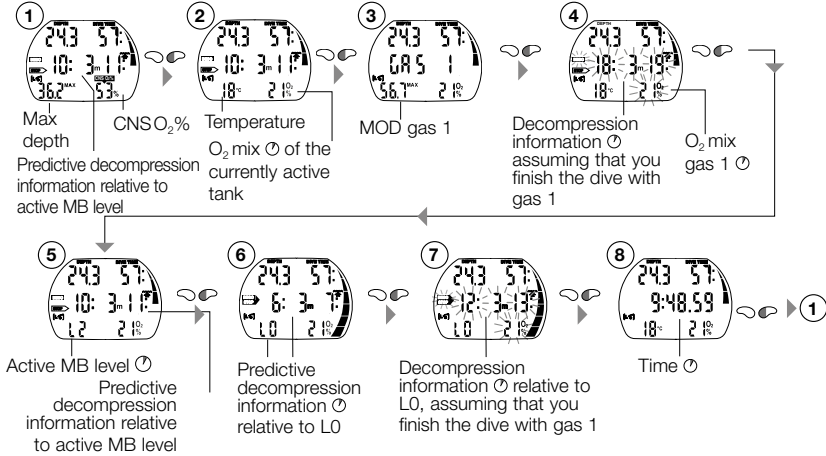

**Gas 2/d active, MB level L1-L5**

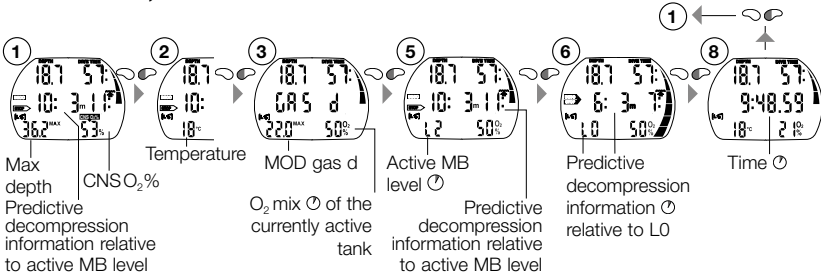

**Changing the gas mixture**

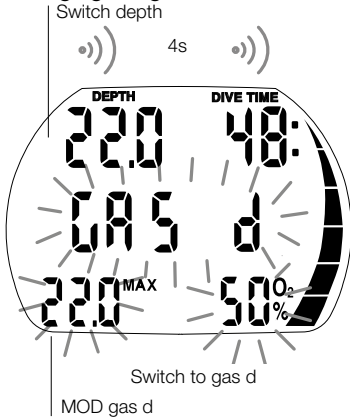

After immersion, Aladin TEC 3G automatically selects gas 1.

**⚠ WARNING**

When during an ascent a switch depth is reached (MOD gas 2 or gas d), an audible warning goes off and “GAS 2” / “GAS d”, its MOD and O2% blink for 30 seconds.

Procedure:

1. Switch to the regulator with gas 2 / gas d and start breathing.
2. Confirm the change by pressing within 30 seconds. “GAS 2” / “GAS d” and the oxygen fraction of gas 2 / gas d is displayed for 5 seconds without blinking.

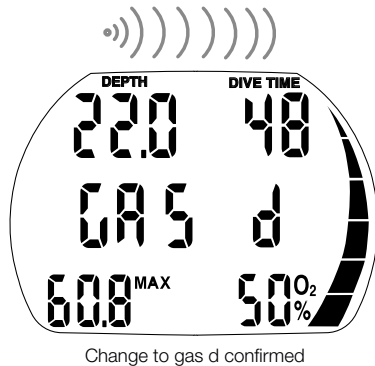

To interrupt the switch process at any point, press so many times until the original gas is again active; or do not confirm the gas change process.

**No change of gas mixture:**

If a diver fails to confirm the change of gas mixture or interrupts the switching procedure by pressing , Aladin TEC 3G displays “GAS 1”/“GAS 2”, the MOD and the oxygen fraction for 5 seconds. Aladin TEC 3G continues to calculate with gas 1 / gas 2 only and adapts the decompression calculation accordingly.

## NOTE:

If after the decompression calculation has readjusted itself to reflect the failed switch the diver goes again below the switch depth (MOD of gas2/gas d), Aladin TEC 3G will revert to the decompression calculation that considers gas2/gas d also, since upon ascending again the diver will have a renewed opportunity to perform the switch once the switch depth is reached.

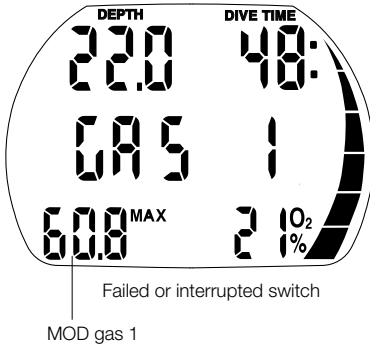
**Belated or manually change of gas mixture:**

A diver can catch up on a required change to gas2 / gas d until he reaches the surface.

1. Initiate the switching process by pressing . Aladin TEC 3G displays "GAS 2"/"GAS d" , MOD and the oxygen fraction of gas2/gas d blinking for 30 seconds. By pressing you can select "GAS 2", "GAS d" or "GAS 1".
2. Switch to the regulator with the selected gas mixture and start breathing.
3. Confirm the change by pressing . "GAS 2", "GAS d" or "GAS 1" and its oxygen fraction is displayed for 5 seconds without blinking. The decompression calculation will readjust accordingly.

**Submerging again after a change to gas 2 / gas d:**

If after a change to gas2/gas d the Maximum Operating Depth (MOD) of gas2/gas d is exceeded, the ppO<sub>2</sub> max warning will appear ->30.

Change back to from gas2 to gas 1 (respectively from deco gas to gas2), which is suited for this depth, or rise to the Maximum Operating Depth of gas2 / gas d. Failure to do so can result in oxygen poisoning.

1. Initiate the switching process by pressing . Aladin TEC 3G displays "GAS 1"/"GAS 2", MOD and the oxygen fraction of gas 1/gas 2 for 30 seconds. By pressing you can select "GAS 2", "GAS 1" or "GAS d".
2. Switch to the regulator with the selected gas and start breathing.
3. Confirm the change by pressing . "GAS 1" / "GAS 2" / "GAS d" and its oxygen fraction is displayed for 5 seconds without blinking. Afterwards the decompression calculation will readjust accordingly.

## 9. CCR DIVING

### Closed Circuit Diving

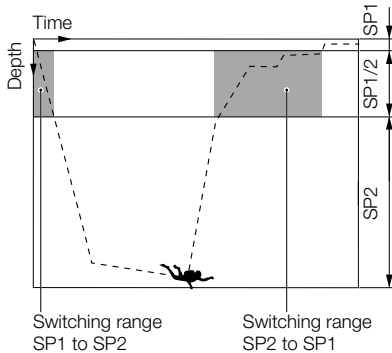

#### NOTE:

*The following chapter deals with the characteristics of CCR diving.*

Aladin TEC 3G enables you to switch between 2 different ppO<sub>2</sub> settings during the same CCR dive (setpoints SP1 and SP2).

In addition a Bail-Out gas mixture can be used which allows to switch from CCR diving to open circuit diving.

### 9.1 Preparation for the CCR dive

You have to check the settings of Aladin TEC 3G especially before the first dive. All settings can be checked and changed directly at Aladin TEC 3G or via LogTRAK.

#### Switching the CCR option on and off

In order to enable CCR diving you must turn on the CCR option in the SET 1 menu ->87.

#### 9.1.1 Setting the ppO<sub>2</sub> and gas mixture

### WARNING

Before every dive and after changing the tank, make sure that the settings for the gas mixture correspond with the current mixture used. An incorrect setting causes Aladin TEC 3G to miscalculate this particular dive. If the fraction of oxygen is set too low this can lead to oxygen poisoning without warning. If the value is set too high decompression sickness may occur. Inaccuracies in the calculations are carried over to repetitive dives.

#### Setting the Setpoints SP1 and SP2

During dives with two setpoint settings the SP1 contains the lower fraction of oxygen. Aladin TEC 3G will only accept settings corresponding with this order.

To set the setpoints SP1 and SP2, Aladin TEC 3G must be in user mode (time of day display).

Procedure:

1. Push or until the SP1 menu appears.
2. Confirm that you wish to change the SP1 settings by pushing .

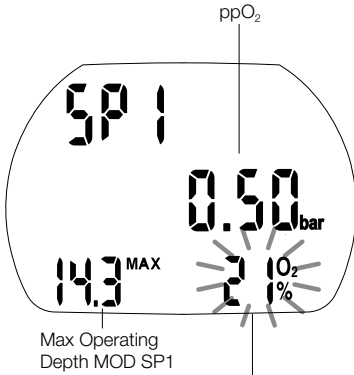

Change the O<sub>2</sub>% mix by (+) and (-)

Set the oxygen fraction of the Diluent gas mixture and the partial pressure (ppO<sub>2</sub>) selected at the CCR:

3. Change the oxygen fraction in increments of 1% by pushing or . Aladin TEC 3G will display the current fraction of oxygen, the partial pressure (ppO<sub>2</sub>) and the MOD.
4. Confirm the selected percentage with .

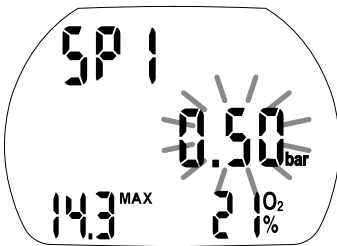



Change the ppO<sub>2</sub> by (+) and (-)

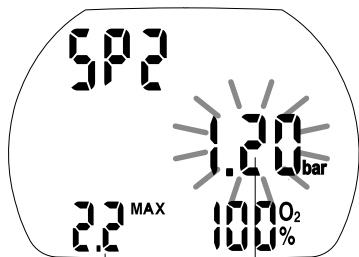

5. By pushing or you can change the ppO<sub>2</sub> in the range of 0.3 to 0.95bar. Aladin TEC 3G will now display the corresponding MOD for the new ppO<sub>2</sub>.
6. Confirm your ppO<sub>2</sub> settings with .
7. Push or until the SP2 menu appears.
8. Confirm that you wish to change the SP2 setting by pushing .



AMD (Absolute Minimum Depth SP2, not allowed to go shallower)

Change the ppO<sub>2</sub> by   (+) and   (-)

Set the partial pressure (ppO<sub>2</sub>) of the bottom setpoint, selected at the CCR:

9. By pushing  or  you can change the ppO<sub>2</sub> in the range of 1.0 to 1.4bar. Aladin TEC 3G will now display the corresponding AMD (Absolute Minimum Depth SP2) for the new ppO<sub>2</sub>.



Note that the MOD SP1 and the AMD (Absolute Minimum Depth SP2) correspond to the depths at which you plan to switch the rebreather settings from shallow water SP1 to bottom SP2 (switch depths SP1 / SP2).

#### NOTE:

- Without confirmation the display will disappear after 3 minutes and your entries will not be accepted.
- During the descent and during the ascent an audible and visual attention message will indicate that you have reached a depth which requires a change at the CCR setpoint settings or vice versa (setpoint 1 / setpoint 2).
- Without confirmation with  the display will disappear after 3 minutes and your entries will not be accepted.
- If CCR is enabled at the SET1 in surface mode and up to a depth of 0.8m Aladin TEC 3G will display "CC" in the lower right corner of the display instead of a percentage value.

### Setting the Bail-Out

To set the Bail-Out gas mixture, Aladin TEC 3G must be in user mode (time of day display).

1. Push  or  until the Bail-Out menu appears.
2. Confirm that you wish to change the oxygen fraction by pushing .

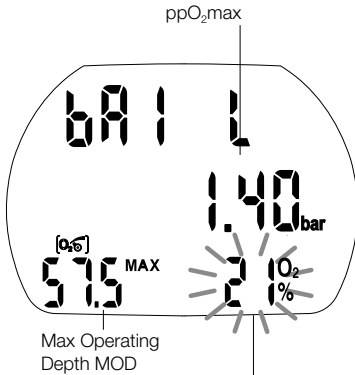

Change the O<sub>2</sub> mix by (+) and (-)

3. Change the oxygen fraction in increments of 1% by pushing or . Aladin TEC 3G will display the current fraction of oxygen, the maximum partial pressure limit (ppO<sub>2</sub> max) and the MOD.
4. Confirm the selected percentage with .

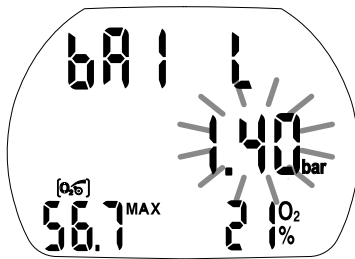

Change the ppO<sub>2</sub> max by (+) and (-)

5. By pushing or you can change the ppO<sub>2</sub> max for the chosen fraction of oxygen down to 1.0bar. Aladin TEC 3G will now display the corresponding MOD for the new ppO<sub>2</sub> max.
6. Confirm your ppO<sub>2</sub> max settings with .

## 9.2 Functions during a CCR dive

### WARNING

During dives with several gas mixtures, always make sure you are breathing from the tank you intended to breath from. Mark all your tanks and regulators, so they can under no circumstances be mixed up! Before every dive and after changing a tank, make sure that each gas mixture is set to the correct value for the corresponding tank.

### Predictive decompression prognosis

The calculation of decompression data is based on the assumption that the SP1/SP2 change(s) will be performed at the previously selected switch depth(s) (setpoint 1/2). If a diver ignores a required change or changes the SP1/SP2 belatedly, Aladin TEC 3G will readjust the decompression calculation accordingly. In case of an ignored switch the dive computer will then base its calculations on the assumption that the diver will ascend to the surface with the currently selected SP1/SP2.

## Alternate displays during a CCR

### NOTE:

*All displays time out after 5 seconds and the default display is shown again. (Only exception is the temperature, screen 2 below.)*

- ① The default display shows the predictive decompression prognosis, which assumes the diver will switch to SP1 at the specified switch depth. In the bottom left corner the temperature is displayed unless the current depth is 1m/3ft shallower than the max depth, in which case the max depth is displayed.
- ② Upon pressing the right button, the temperature and the current  $ppO_2$  are shown in the lower row.  $ppO_2$  will time out after 5 sec while the temperature remains.
- ③ Upon pressing the right button, "SP 1" appears in the middle row to indicate the currently active gas and the AMD (Absolute Minimum Depth SP2) appears in the bottom left corner. "SP 1" will time out after 5 seconds unless the right button is pressed again.
- ④ In case that SP1 is active, pressing the right button one more time shows  $ppO_2\%$  in the bottom right corner and the decompression information in case SP2 not used (decompression information relative to SP1 only). This is the calculation that Aladin TEC 3G would switch to in case, having reached the switch depth, the diver did not confirm the switch. The decompression information and the  $O_2\%$  blink.
- ⑤ If an MB level greater than L0 is active, pressing the right button one more time shows the predictive decompression information and in the bottom left corner the currently active MB level.
- ⑥ Pressing the right button again shows the predictive decompression information relative to L0 together with the L0 symbol at the bottom left.
- ⑦ One more right button push shows the decompression information relative to L0 if only the SP1 is used, with the decompression information and the  $ppO_2$  of the SP1 blinking.
- ⑧ Upon pressing the right button again, the time of day appears in the middle row.

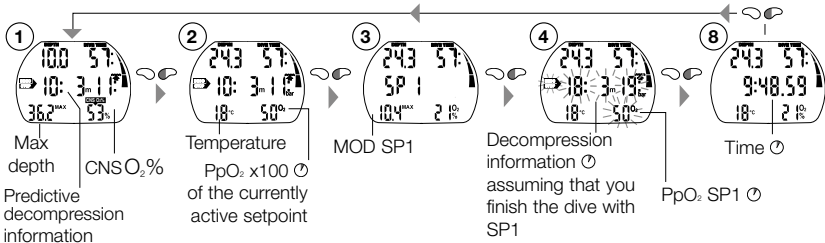
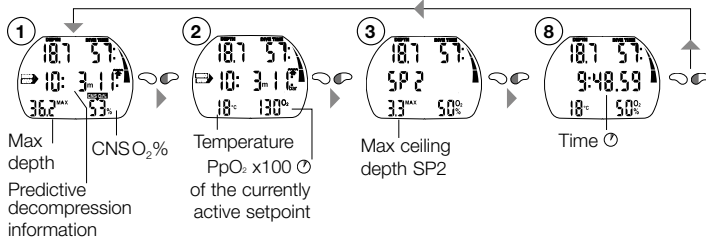
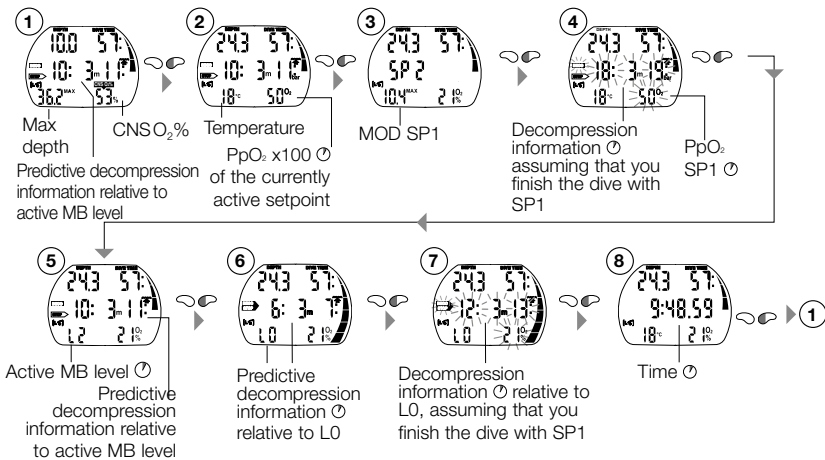
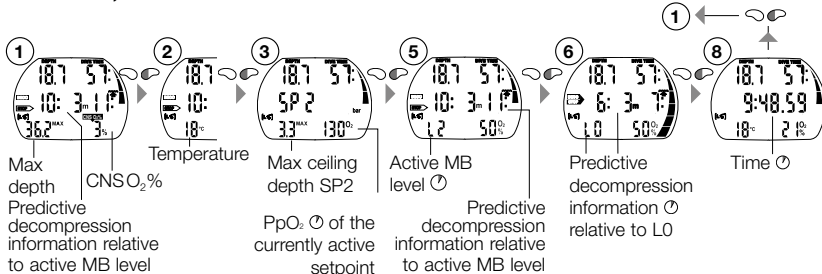

**SP1 active, MB level L0**

**SP2 active, MB level L0**

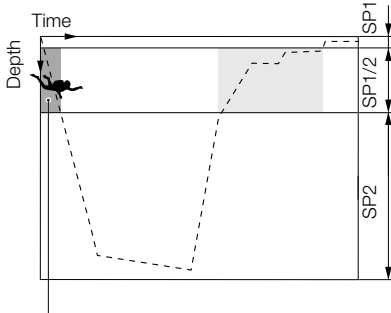
**SP1 active, MB level L1-L5**

**SP2 active, MB level L1-L5**

**Changing from dive start setpoint (SP1) to the bottom setpoint (SP2), (descending)**

After immersion, Aladin TEC 3G automatically starts the dive with SP1.



Switching range form SP1 to SP2

**⚠ WARNING**

When the switch depth is reached an audible warning goes off and MOD blinks as long as the current depth is below MOD. Below SP1 MOD, Aladin TEC 3G calculates according to SP1  $ppO_2$  content; this may lead to long decompression requirement since nitrogen fraction increases above the diluent content.

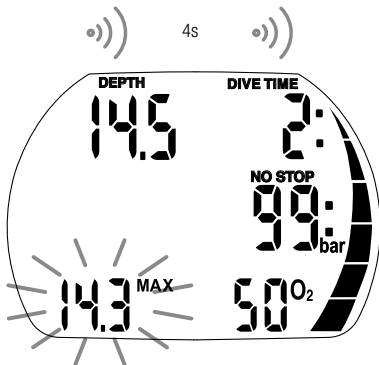

Max Operating Depth MOD SP1 reached,  
Switch to SP2

Procedure:

1. Switch your CCR from SP1 to SP2.
2. Start the change by pressing . "SP2", its MOD (not allowed to go shallower) and the set  $ppO_2$  is displayed.

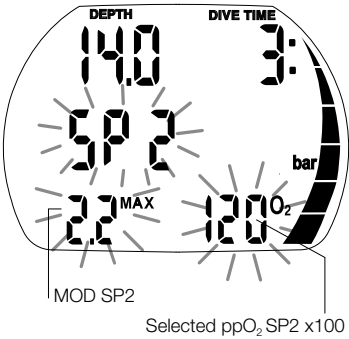

3. Press to confirm the switch. The text is shown for 5 seconds without blinking.

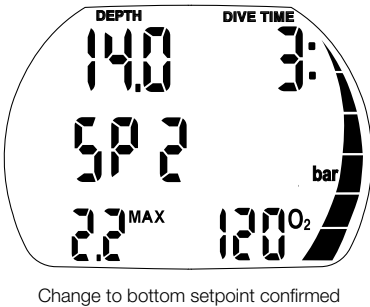

To interrupt the switch process at any point, press 2x .

**Changing form bottom SP2 to SP1**

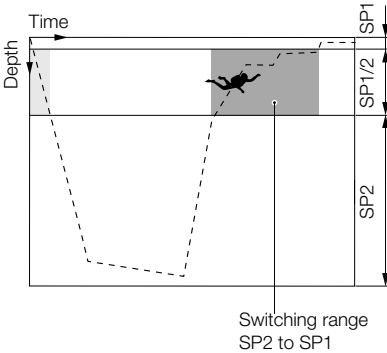

**⚠ WARNING**

When ascending the AMD (Absolute Minimum Depth SP2) switch depth is reached an audible warning goes off and “SP1”, its MOD and the set ppO<sub>2</sub> blink for 30 seconds.

Procedure:

1. Switch your CCR from SP2 to SP1 and start breathing.
2. Confirm the change by pressing  within 30 seconds. "SP1" and the oxygen fraction of the Diluent is displayed for 5 seconds without blinking.

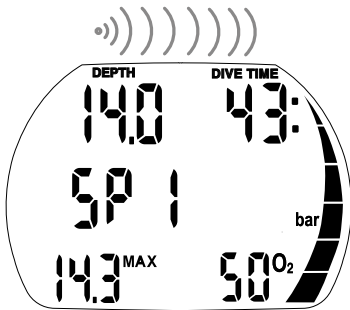

Change to SP1 confirmed

To interrupt the switch process at any point, press 2x .

### No change of gas setting at ascent:



If a diver fails to confirm the change of setpoint or interrupts the switching procedure by pressing 2x , Aladin TEC 3G displays "SP2", the MOD and the ppO<sub>2</sub> for 5 seconds. Aladin TEC 3G continues to calculate with rebreather injecting 100% Oxygen (maximum reached ppO<sub>2</sub> depends on ambient pressure) and adapts the decompression calculation accordingly.

 NOTE:

*If after the decompression calculation has readjusted itself to reflect the failed switch the diver goes again below/above the switchpoint SP1/SP2, Aladin TEC 3G will revert to the decompression calculation that considers SP1/SP2 also, since upon ascending again the diver will have a renewed opportunity to perform the switch once the switch depth is reached.*

### Belated or manual change of setpoint:



A diver can catch up on a required change to SP1 / SP2 until he reaches the surface.

1. Initiate the switching process by pressing . Aladin TEC 3G displays "SP1" or "SP2" blinking for 30 seconds.
2. Switch the rebreather settings accordingly.
3. Confirm the change by pressing . SP1/SP2 and its MOD and ppO<sub>2</sub> is displayed for 5 seconds without blinking. The decompression calculation will readjust accordingly. (Press  to interrupt the switch process at any time.)

### Submerging again after a change to SP1:







If after a change to SP1 the Maximum Operating Depth (MOD) of SP1 is exceeded, the ppO<sub>2</sub> max warning will appear ->30.

Change back to from SP1 to SP2, which is suited for this depth, or rise to the Maximum Operating Depth of SP1. Failure to do so can result in oxygen poisoning.

1. Initiate the switching process by pressing . Aladin TEC 3G displays "SP2", MOD and the ppO<sub>2</sub> for 30 seconds.
2. Switch the rebreather settings from shallow water SP1 to bottom SP2 and start breathing.
3. Confirm the change by pressing . "SP2" and the ppO<sub>2</sub> and MOD of SP2 is displayed for 5 seconds without blinking. Afterwards the decompression calculation will readjust accordingly.

### Switching SP1 or SP2 to Bail-Out

A diver can switch to the Bail-Out at any time.

1. Initiate the switching process by pressing  . Aladin TEC 3G displays "SP1" or "SP2" for 30 seconds.  
Scroll with   until Aladin TEC 3G displays "bail".
2. Switch to the regulator with the Bail-Out and start breathing.
3. Confirm the change by pressing  . "Bail") and its oxygen fraction is displayed for 5 seconds without blinking. The decompression calculation will readjust accordingly.

## 10. DIVE PLANNER

Aladin TEC 3G has a dive planner which allows the planning of no-stop dives and decompression dives.

Basis of the planning:

- selected fraction of oxygen and MOD
- selected water type
- selected MB level
- water temperature of the most recent dive
- altitude range (if any)
- status of saturation at the time the dive planner is selected
- assuming a normal workload of the diver and observance of the prescribed ascent rates
- $\dot{V}_E$  assumption: the change to gas 2/d is performed at the selected MOD of gas 2/d.
- CCR: assumption: the gas changes are performed at the selected setpoints (SP1 and SP2).

### 10.1 Planning a no-stop dive

To select the dive planner Aladin TEC 3G must be in user mode (**time of day display**). Push or until the symbol for the dive planner PLn appears. (The dive planner cannot be selected in gauge mode.)

Select dive planner  
 or   
 until PLn

The no-dive warning and its duration are displayed if Aladin TEC 3G detects an increased risk due to the accumulation of microbubbles.

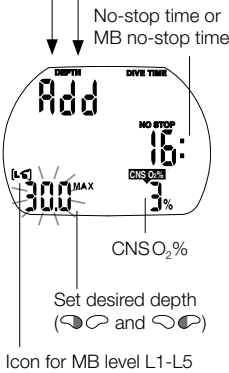
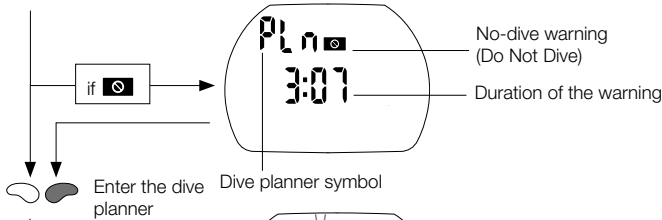

Enter the dive planner with .

The input window for the time interval is displayed if there was a remaining desaturation (DESAT) before the dive planner has been selected. This surface interval between now and the beginning of the dive can be changed with and in steps of 15 minutes. Aladin TEC 3G displays the CNSO<sub>2</sub>% value and the altitude section to which you may not rise at the end of the selected surface interval.

If the no-dive warning and its duration has been displayed, Aladin TEC 3G proposes this time – rounded up to the next 15 minutes – as surface interval. If the proposed interval is shortened, the no-dive warning appears.

Confirm the displayed interval with (if applicable).  
 With and set the depth for which you want to know the no-stop time.

If an MB level has been selected (L1-L5), the MB no-stop time is shown.

Depths deeper than the MOD for the selected gas (O<sub>2</sub> mix) are not displayed.

If the deco gas option is turned on, only the depth between the MOD of gas 1 and the MOD of gas 2 are displayed.

On page 36 you will find further information and safety considerations regarding the no-dive warning.

## 10.2 Planning a decompression dive

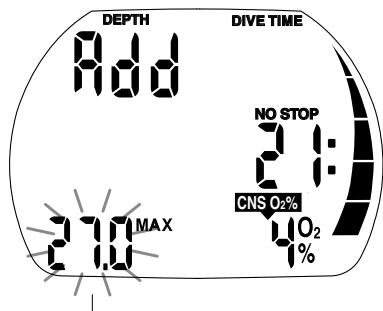

Confirm the desired depth with

1. Activate the dive planner for a no-stop dive ->77.
2. Set the desired depth with and , then switch into decompression planning by pushing . Aladin TEC 3G shows the bottom time (no-stop time + 1 minute) and the appropriate decompression information or level stop data respectively.

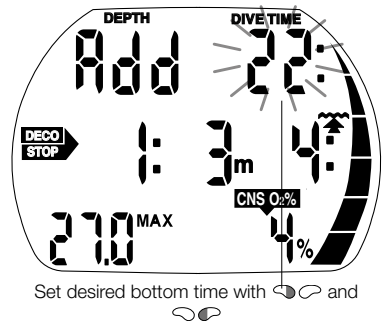

Set desired bottom time with and

3. "Add" asks that you set the bottom time. This is done with and . Aladin TEC 3G calculates the decompression information for this set bottom time. If an MB level (L1-5) is selected, Aladin TEC 3G calculates the level stop data.

CNS O<sub>2</sub>% values higher than 199% will be displayed as 199 %.

Ascent time greater than 99 minutes is displayed as "--"

Deco stop depth deeper than 27m (90ft) is displayed as "-- : --"

CNS O<sub>2</sub> equal or greater than 75%: CNS O<sub>2</sub>% symbol starts flashing

CNS O<sub>2</sub> equal or greater than 100%: CNS O<sub>2</sub>% symbol and CNS O<sub>2</sub>% value are flashing.

MB level stop deeper than 27m (90ft): MB level will be reduced.



### 10.3 *Leaving the dive planner*

By pushing once or twice  you can exit the dive planner. This also occurs after three minutes without operation.

## 11. LOGBOOK

### 11.1 Survey

A dive is entered in the logbook if the dive time is longer than 2 minutes. Aladin TEC 3G records the profiles of about 25 hours of diving. In Apnea mode all dives are entered in the logbook without time limit and at least 6h of Apnea profiles will be stored. This information can be transferred to a PC with the standard infrared interface (IrDA) and the Windows® software LogTRAK. All dives in the memory can be displayed directly on the dive computer.

### 11.2 Operation

From the **time of day display** you can select the logbook with .

until

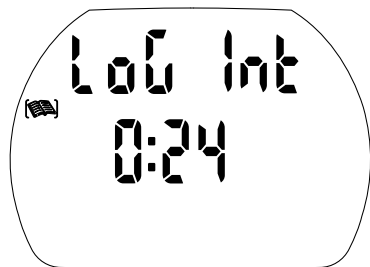

Surface interval



If there was a remaining desaturation time (DESAT) before selecting the logbook, the time since the last dive (surface interval) is displayed.

#### Page 1

With you enter the logbook.

The most recent dive is displayed (dive number 1).

There are 3 pages for each dive.

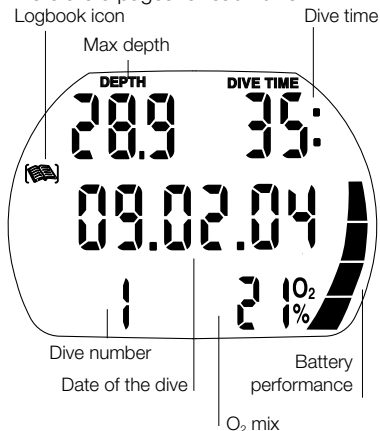



From here you can:

a) get more information about the displayed dive by pushing (see below, "page 2"). Aladin TEC

3G displays further information about the selected dive.

b)select other dives.

Each time you push  or  causes a jump to the next or previous dive.

At the end of the logbook Aladin TEC 3G displays statistic information ->83.

**Page 2**

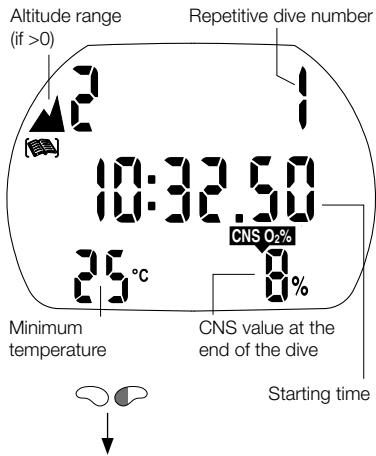

Push  to get more information about the dive.

**Page 3**

If a dive is started within adaptation time (after a change of altitude), the adaptation time is displayed instead of the surface interval.

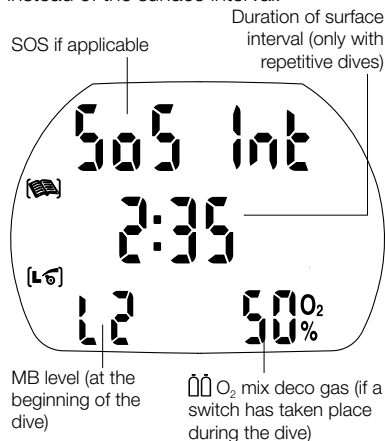

Further possible information about the dive:

- Too fast ascent\* (page 1)
- Ignored decompression stop\* (page 1)
- Ignored decompression stop\* (page 3)
- Diving in SOS mode (gauge mode) (page 3)
- Altitude range (page 2)
- MB level dive (L1-L5) (page 3)
- Ignored MB level stop\* (page 1)
- DESAT Desaturation was reset before the dive (in "set 1") (page 1, 2)
- Desaturation was reset before the dive by removing the battery (page 1, 2)
- DESAT Battery quality factor has been 3 bars or less during the dive (page 1, 2, 3)
- Diving in gauge (page 1, 2, 3)
- AVG Average depth (gauge mode) (page 3)
- No-dive warning after the dive (page 1)
- Apnea mode dive (page 44)

\*Alarms during the dive

↶ gets you back to the dive list (first level screen within logbook). From here you can advance to the next dive of interest and press ↷ to retrieve more information about that dive etc.

**Statistic information**

From the **time of day display** you can get the following statistic information over all dives. Push ↶, ↷ and ↶↷:

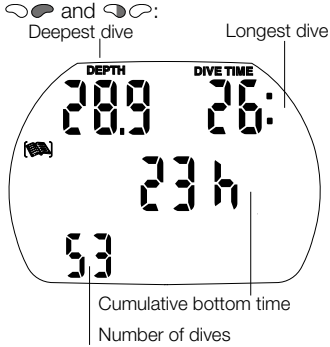

**Leaving the logbook**

By pushing once or twice ↶ you can exit the logbook.

The logbook closes automatically after 3 minutes without operation.





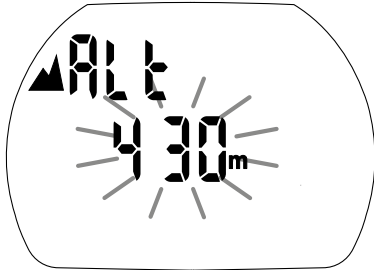

## 12. SETTINGS

### 12.1 Altitude adjustment

The altitude adjustment does not affect altitude ranges nor any calculations.



Adjust the altitude indication to your current altitude.

1. Starting from the **time of day display** push  or  until the mountain symbol and the altitude appear.
2. Confirm that you wish to change the displayed altitude by pushing  .  
The altitude starts to flash.
3. Change the altitude in increments of 10m / 50ft by pushing  or .
4. Confirm the selected altitude with .

### 12.2 Menu “set 1”

With menu “set 1” or LogTRAK you can configure the following items (dive functions):

Setting	Range	Default	Page
• CCR mode	on / off	off	85
• Depth alarm	5-100m (20 - 330ft) on/off	40m (130ft),off	85
• Dive time alarm	5-195min, on/off	40m (130ft),off	86
• Safety stop duration	1-5min	3 minutes	86
• Maximum partial pressure of oxygen (ppO <sub>2</sub> max)	1.2-1.6bar	1.4bar	86
• Time limit to reset the O <sub>2</sub> % mix to air	no reset / 1 - 48hrs	no reset	86
• Deco gas	on/off	off	87
• PDIS (Profile Dependent Intermediate Stop)	on/off	off	87
• Unit system	metric/imperial		87
• Water type	on (salt water)/off (fresh water)	on (salt water)	88
• Backlight illumination duration	2-12s ; push on / push off	6s	88
• Audible attention signals	on / off (LogTRAK: selective)	on	89
• Water contacts	on / off	on	89
• Reset desaturation	on / off	no reset	90

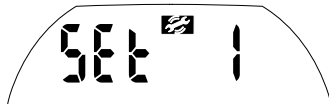

Starting from the time of day display push or until "set 1" appears. Confirm that you wish to enter into the menu of "set 1" by pushing . Once entered into the menu you can scroll with and through the menu.

### Enabling CCR

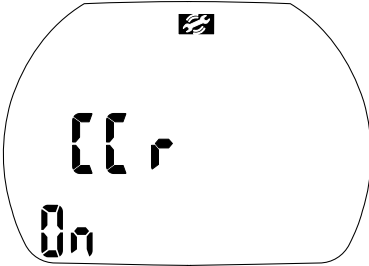

1. Confirm that you wish to enable CCR diving by pushing . "On" or "off" starts to flash. "On" indicates the deco gas is active, "off" indicates that only gas 1 will be used for decompression calculations.
2. Switch between "on" and "off" with .
3. Confirm your choice with .

### Setting the depth alarm

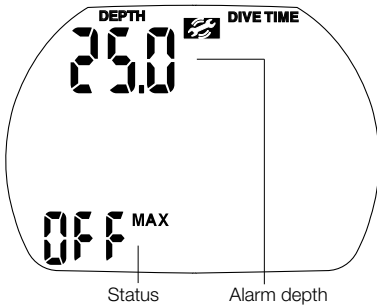





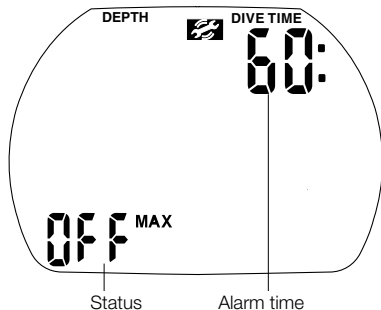

1. Confirm that you wish to change the depth of the alarm or to switch it on or off by pushing . The depth starts to flash.
2. Change the depth in increments of 1 m/5 ft by pushing or .
3. Confirm the selected depth with . "On" or "Off" starts to flash.
4. "On" indicates "activated", "Off" indicates "deactivated".  
 switches between "On" and "Off".  
 Confirm the selected status with .

See also page 28.





### Setting the dive time alarm

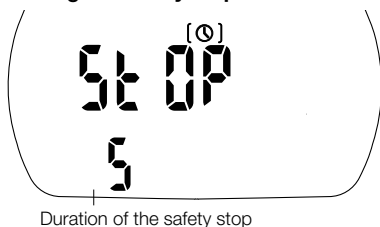

1. Confirm that you wish to change the time of the dive time alarm or to switch it on or off by pushing . The alarm time starts to flash.
2. Change the alarm time in increments of 5 minutes by pushing  or .
3. Confirm the selected alarm time with . "On" or "Off" starts to flash.
4. "On" indicates "activated", "Off" indicates "deactivated".  
Switch between "on" or "off" by pressing .  
Confirm the selected status with . See also page 27,27.





### Setting the safety stop duration

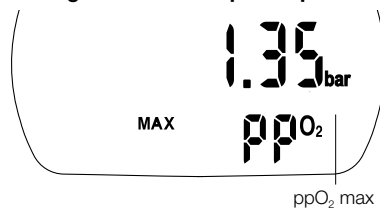

1. Confirm that you wish to change the duration of the safety stop by pushing . The duration starts to flash.
2. Change the duration in increments of 1 minute or to off (inactive) by pushing  or .
3. Confirm the selected duration with .

### Setting the maximum partial pressure of oxygen (ppO<sub>2</sub> max)



1. Confirm that you wish to change the ppO<sub>2</sub> max by pushing . The current value starts to flash.
2. Change the value in increments of 0.05bar by pushing  or .
3. Confirm the selected value with .

The ppO<sub>2</sub> max setting is valid for gas 1 and the deco gas.

### Setting the time limit to reset the O<sub>2</sub>% mix to air



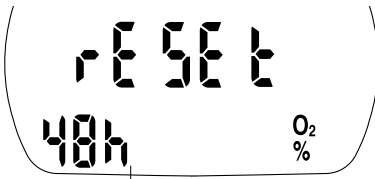

Time limit to reset O<sub>2</sub> mix to air

1. Confirm that you wish to change the time limit of the reset by pushing . The current setting starts to flash.
2. Change the time limit by pushing or .
- (1 - 48hrs or no reset: "-- h")
3. Confirm the selected value with .

### Enabling two-gas diving

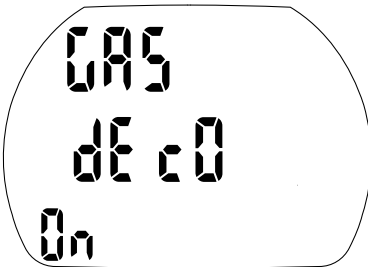

1. Confirm that you wish to enable two-gas diving by pushing . "On" or "off" starts to flash. "On" indicates the deco gas is active, "off" indicates that only gas 1 will be used for decompression calculations.
2. Switch between "on" and "off" with .
3. Confirm your choice with .







### PDIS (Profile Dependent Intermediate Stop)

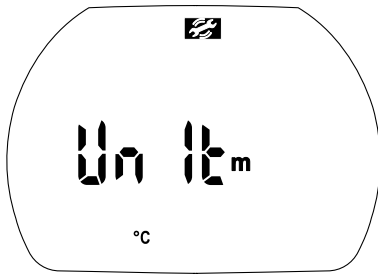

1. Confirm that you wish to enable PDIS by pushing . "On" or "off" starts to flash. "On" indicates that the PDIS timer will be automatically activated during the dive, "off" indicates that PDIS will be inactive.
2. Switch between "on" and "off" with .
3. Confirm your choice with .



### Selecting the units



1. Confirm that you wish to change the units by pushing . The selected units are displayed (m / ft / °C / °F).
2. Push . "m" or "ft" starts to flash.
3. Switch with  between "m" and "ft".
4. Confirm the selected unit with . "°C" or "°F" starts to flash.
5. Switch with  between "°C" and "°F".
6. Confirm the selected unit with .

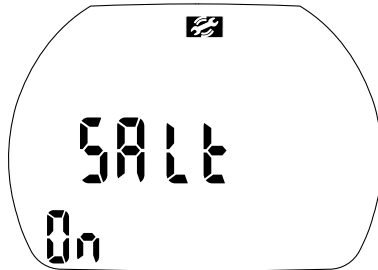

### Selecting the water type

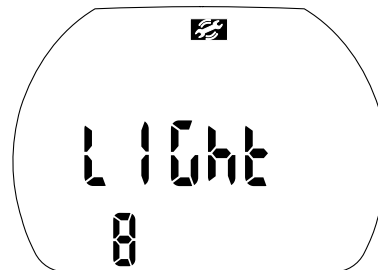

1. Confirm that you wish to change the selected water type by pushing . "On" or "off" starts to flash.  
"Salt on" indicates salt water, "salt off" indicates fresh water.
2. Switch with  between "salt on" and "salt off".  
Confirm the water type with .

### Setting the backlight duration



1. Confirm that you wish to change the duration of the backlight illumination by pushing .  
The value starts to flash.
2. Change the duration with . (2-12s or push on / push off)
3. Confirm it with .

**Switching the audible attention signals on and off**

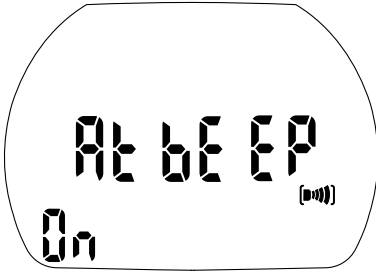

With this option you can switch off the audible attention signals only (the audible alarms remain active). Refer to page 23 to see this distinction.

1. Confirm that you wish to change the setting of the audible attention signals by pushing .
- "On" or "off" starts to flash.
2. Switch between "on" or "off" by pressing .
3. Confirm the setting with .

## Switching the water contacts on and off

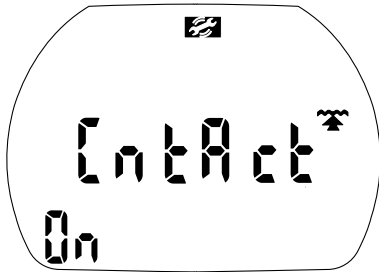



On submerging in water the water contacts switch on Aladin TEC 3G automatically.

### WARNING

If you chose the option “Water contacts off”, Aladin TEC 3G will turn on with a delay of up to 1 minute into the dive. This will affect functioning of the computer.

Make sure that the computer is on before starting the dive.

1. Confirm that you wish to change the setting of the water contacts by pushing . “On” or “off” starts to flash.
2. Switch between “on” or “off” by pressing .
3. Confirm the setting with .

## Resetting the remaining saturation

### WARNING

Diving after a reset of the remaining saturation may lead you into potentially hazardous situations which could result in death or serious injury.

After a reset of the remaining saturation do not dive for at least 48 hours.

If you dive after resetting the remaining saturation the computer will miscalculate your decompression, which may result in serious injury or death. Reset the remaining saturation only if you know you will not be diving, flying or going to higher altitude for the next 48 hours.

Resetting the desaturation should only be done when there is a valid reason, e.g. loaning the computer to somebody who has not dived in 48 hours or more. When the computer itself has remaining saturation you must assume full responsibility for the consequences of resetting the remaining saturation.

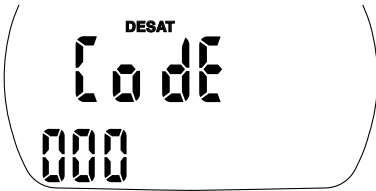

1. Confirm that you wish to reset the displayed saturation by pushing . "On" starts to flash.
2. Switch between "on" or "off" by pressing .
3. Confirm the setting with . If you have selected "off", "Code" and "000" appear.
4. Set the first digit by pushing and . Confirm with .

Repeat point 4 for the next 2 digits. If you entered the right code the desaturation will be reset to zero (desat off). Code: 313

### 12.3 Menu "set 2"

With menu "set 2" or LogTRAK you can configure the following items:

Setting	Range	Default	Page
• Alarm clock	0 - 23h 59min, on/off	12:00, off	92
• UTC (Universal Time Change) zone	±13hrs, increments: 15min		92
• Time of day	hours:minutes		92
• 24 or AM/PM setting	24 (off) / AM/PM (on)		93
• Date			93
• Display contrast	1 (low) -12 (high)	4	94
• IrDA speed setting (only "set 2")	low / high	low	94
• Sound	on / off	on	94
• Show Aladin TEC 3G electronic ID			95

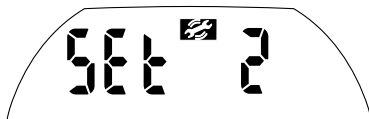

Starting from the time of day display push or until "set 2" appears.















Confirm that you wish to enter into the menu of "set 2" by pushing .

Once entered into the menu you can scroll with and through the menu.

### Setting the alarm clock time









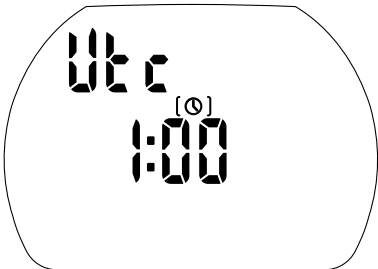



The alarm clock goes off only at the surface. “Sound” must be turned “on” in “set 2”.

1. Confirm that you wish to set the alarm time by pushing  .
- The hours start to flash.
2. Set the hours by pushing   or .
3. Confirm the setting with  .
4. Set the minutes by pushing  or .
5. Confirm the setting with  .
6. “On” indicates “activated” (time of day display shows  ), “off” indicates “deactivated”.
- Switch between “on” or “off” by pressing .
7. Confirm the selected status with  .

### Setting the UTC offset (coordinated universal time)



This setting allows you to quickly set the watch to a new time zone without affecting the actual time setting.

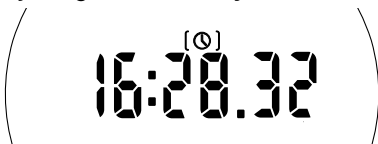

1. Confirm that you wish to set the UTC offset by pushing  .
- The hours start to flash.
2. Set the hours by pushing   or  (±13hrs).
3. Confirm the setting with  .
4. Set the minutes in increments of 15 minutes by pushing  or .
5. Confirm the selected status with  .

### Adjusting the time of day









Time of day

You can adjust it to your time zone either in this menu or using the UTC offset (see above).



1. Confirm that you wish to adjust the time of day by pushing  .

The hours start to flash.

2. Set the hours by pushing  or .
3. Confirm the setting with . The minutes start to flash.
4. Set the minutes by pushing  or .
5. Confirm the setting with .

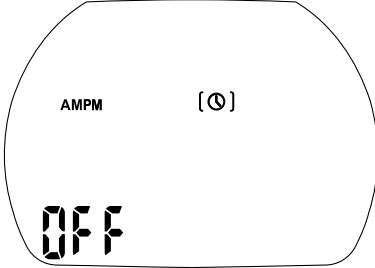
### Selecting 24 hours or AM/PM setting



1. Confirm that you wish to change the setting by pushing . "On" or "off" starts to flash.
2. Switch with  between "on" (AM/PM) and "off" (24h).
3. Confirm the setting with .

The 24h - AM/PM setting influences the display of the date (see below).









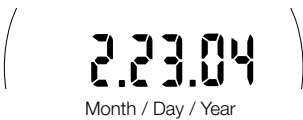

### Adjusting the date

Date (24h setting)









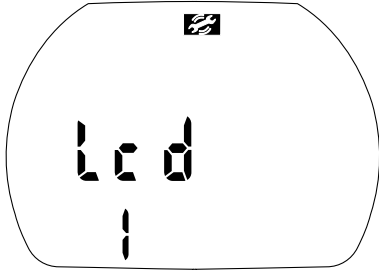

Date (AM/PM setting)



1. Confirm that you wish to adjust the date by pushing .
2. Set the day (month) by pushing  or .
3. Confirm the setting with . The month (day) starts to flash.
4. Set the month (day) by pushing  or .
5. Confirm the setting with . The year starts to flash.
6. Set the year by pushing  or .
7. Confirm the setting with .

### Adjusting the display contrast







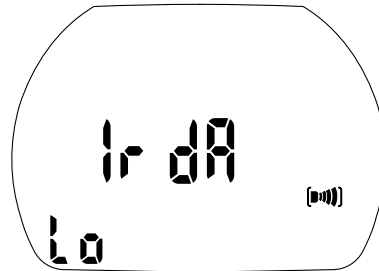

1. Confirm that you wish to adjust the display contrast by pushing  .  
The current setting starts to flash.
2. Set the contrast by pushing   or  .
3. Confirm the setting with  .

### Selecting the IrDA speed



The default setting is low. For faster downloads you can set it to high, but not all IrDA interfaces are compatible with high.

1. Confirm that you wish to change the IrDA speed by pushing  . "Lo" (low) or "hi" (high) starts to flash.
2. Switch with   between low and high.
3. Confirm the setting with  .

Low: 9600 bits/second

High: max 57 600 bits/second

### Switching the sound on and off

#### **WARNING**

If you turn off the sound, the buzzer is effectively deactivated. You will have no audible warnings (alarms and attention messages)! Without audible warning you could get into potentially hazardous situations, which could result in death or serious injury.

You must assume full responsibility for turning off the sound.



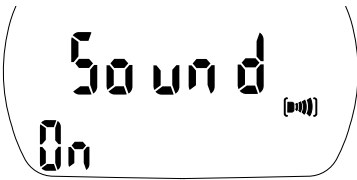

1. Confirm that you wish to change the setting by pushing . "On" or "off" starts to flash.
2. Switch with between "on" and "off".
3. Confirm the setting with . If you have selected "off", "Code" and "000" appear.
4. Set the first digit by pushing and . Confirm with .

Repeat point 4 for the next 2 digits. If you entered the right code the sound will be turned off.  
Code: 313

NOTE:

*Setting the "sound" to "off" applies also to surface functions (mountain alarm, wake-up alarm, change of altitude range).*

### Showing the hardware electronic ID of Aladin TEC 3G

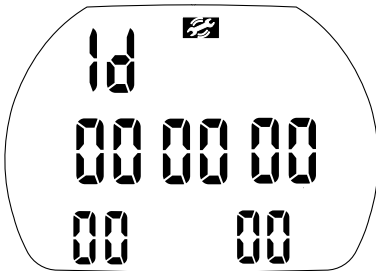

ID Number



This number is needed when reporting problems or for other maintenance related issues.

## 12.4 Menu "set 3" (Apnea)

With menu "set 3" or LogTRAK you can configure the following items:

Setting	Range	Default	Page
Dual Depth alarm	5-100m, 5-100m, on/off	10m (35ft), off 20m (65ft), off	96
Incremental depth alarm	5-100m, dn(down)/ up/ bth(both)/off	5.0m (20ft), off	96

Dive time interval warning	15s-10min, on/off	30s, off	97
Surface interval warning	15s-10min, on/off	1 min, off	97
Ascent speed alarm	0.1-5 m/s, (1-15 ft/s) on/off	1 m/s (3 ft/s), off	98
Water density	1.000-1.050 kg/l (Fresh water ~1.000, Ocean ~1.035)	1.025 kg/l	98

Starting from the time of the display push  or  until “set 3” appears.

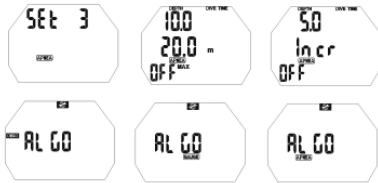









Confirm that you wish to enter into the menu of “set 3” by pushing .

Once entered into the menu you can scroll with  and  through the menu.

### Setting the Dual Depth alarm







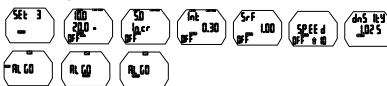

With this alarm you can set two independent depth alarms.

1. Confirm that you wish to change the settings of the Dual Depth alarm by pushing . First depth value starts to flash.
2. Scroll first depth with  or .
3. Confirm the first depth alarm with . Second depth alarm starts to flash.
4. Scroll second depth with  or .
5. Confirm the second depth alarm with . On/off starts to flash.
6. Switch between on/off with .
7. Confirm the setting with .

### Setting the incremental depth alarm



With this alarm you can set repetitive depth alarms at given depth increments.

1. Confirm that you wish to change the settings of the incremental depth alarm by pushing . Increment value starts to flash.
2. Scroll value with  or .
3. Confirm the increment with . Up/Down/Both/Off starts to flash.
4. Switch between Up/Down/Both/Off with .
5. Confirm the setting with .

### Setting the dive time interval warning

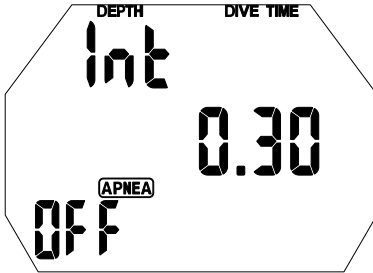

With this alarm you can set time alarm that repeats on given intervals.

1. Confirm that you wish to change the settings of the dive time interval warning by pushing . Interval value starts to flash.
2. Scroll time value with or .
3. Confirm the interval time with . On/off starts to flash.
4. Switch between on/off with .
5. Confirm the setting with .

### Setting the Surface Interval warning

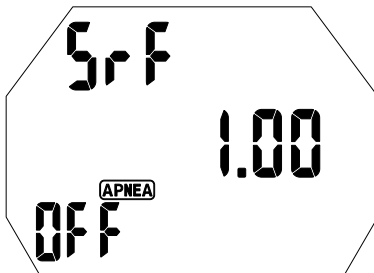







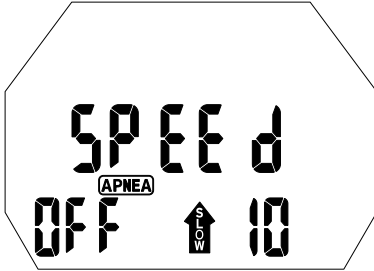

With this alarm you can set a time for recovery or start time for repetitive dive when training against given tables.

1. Confirm that you wish to change the settings of the Surface Interval warning by pushing . Time value starts to flash.
2. Scroll time value with or .
3. Confirm the surface time with . On/off starts to flash.
4. Switch between on/off with .
5. Confirm the setting with .

### Setting the Ascent Speed alarm





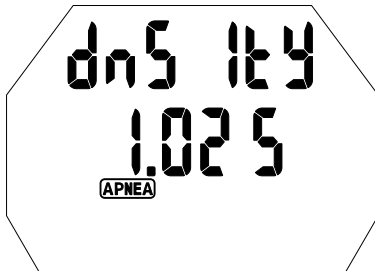

With this alarm you can set ascent speed alarm.

1. Confirm that you wish to change the settings of the Ascent Speed alarm by pushing  .
- Time value starts to flash.
2. Scroll ascent speed value with  or .
3. Confirm the maximum ascent speed with  . On/off starts to flash.
4. Switch between on/off with .
5. Confirm the setting with .

### Setting the Water Density



With this setting you can get optimized accuracy on depth reading when you know the salinity of the water.

1. Confirm that you wish to change the settings of the Water Density by pushing  .
- Density value starts to flash.
2. Scroll density value with  or .
3. Confirm the setting with .

## 13. APPENDIX

### 13.1 Technical information

**Operating altitude:** with decompression information: sea level up to approx. 4000m (13000ft); without decompression (gauge mode): unlimited.

**Max displayed depth:** 120m (395ft), resolution between 0.8m and 99.9m: 0.1m, >99.9m: 1m. The resolution in feet is always 1 foot.

**Decompression calculation depth range:** 0.8 to 120m (3 to 395ft)

**Maximum environment pressure:** 13bar (189psi)

**Clock:** Quartz clock, time, date, dive time display up to 199 minutes.

**O<sub>2</sub> concentration:** Adjustable between 21%O<sub>2</sub> (compressed air) and 100% O<sub>2</sub>

**Operating temperature:** -10° to +50°C (14°F to 122°F).

**Power supply:** CR2450, recommended brands: PANASONIC, DURACELL, RENATA, ENERGIZER, SONY, VARTA.

**Life of the battery:** 2-3 years or 200-300 dives. Actual life of the battery depends on the quantity of dives per year, the use of the backlight and the length of the dives. In cold water the life of the battery is reduced. Not all CR2450 batteries are the same, and low quality batteries can have very short life.

### 13.2 Maintenance

Aladin TEC 3G is virtually maintenance free. All you need to do is to rinse it carefully with fresh water after each use and to have the batteries changed when needed ->99. To avoid possible problems with your Aladin TEC 3G, the following recommendations will help assure that it will give you years of trouble free service:

#### WARNING

- Avoid dropping or jarring your Aladin TEC 3G.
- Do not allow your Aladin TEC 3G to be exposed to direct, intense sunlight.
- Rinse your Aladin TEC 3G thoroughly with fresh water after each dive.
- Do not store your Aladin TEC 3G in a sealed container; make sure there is free ventilation.
- If there are problems with the water contacts, use soapy water to clean Aladin TEC 3G and dry it thoroughly. The surface of your Aladin TEC 3G housing can be treated with silicone grease. Do not apply grease to the water contacts!
- Do not clean Aladin TEC 3G with liquids containing solvent (apart from water).
- Check the battery capacity before each dive ->17.
- If the battery icon appears, replace the battery ->99.
- Diving with a weak battery: Aladin TEC 3G may stop working during the dive, service icon and error code "E3" or "E6" appear. Close the dive and replace the battery ->99.
- On the surface: if service icon and error code "E3" appear, replace the battery ->99. All error codes other than E3: Aladin TEC 3G must not be used for any further dives. Take your dive computer to an authorized Scubapro UWATEC dealer.



#### 13.2.1 Replacing the battery

(Use only the original Scubapro battery kit with O-ring.)

## ⚠ WARNING

Removing the battery clears all physiological data including saturation. This means that for a repetitive dive the computer will not compute correctly. Diving after replacing the battery when there is desaturation time left on the computer can lead to serious injury or death from decompression sickness.

Change the battery only under these conditions:

- After a dive if you know you will not be diving, flying or going to higher altitude for the next 48 hours.
- Before a dive if there is no desaturation time left on the computer.

The change must be made with particular care in order to prevent water from seeping in. The warranty does not cover damages due to an improper replacement of the battery.

## ⚠ WARNING

Never touch the metal surface of the battery with bare fingers.

The two battery poles must never be short circuited.

Procedure:

To replace the battery you need a coin or the Scubapro universal tool and a clean cloth.

## ⚠ WARNING

- A leaking battery cap may lead to the destruction of Aladin TEC 3G by water seeping in or cause Aladin TEC 3G to switch off without prior notice.
- Always open the battery compartment in a dry and clean environment.
- Only open the battery compartment to replace the battery.



1. Dry Aladin TEC 3G with a soft towel.
2. Turn the battery cap with a coin or with the Scubapro universal tool.
3. Remove the battery cap.
4. Remove the O-ring carefully. Do not damage the sealing surfaces.
5. Remove the battery. Do not touch the contacts.

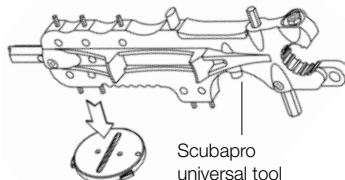

NOTE:

*Protect the environment and dispose the battery properly.*

**⚠ WARNING**

**If you notice traces of seeping water, damages, or other defects on the oring, do not use Aladin TEC 3G for further dives. Take it to an authorized Scubapro UWATEC dealer for check and repair.**

6. Always insert a new O-ring when you replace the battery and dispose the old O-ring. Make sure that the new O-ring is in perfect condition, and that O-ring, O-ring groove and the sealing surfaces are free of dust and dirt. If necessary, clean the parts with a soft cloth. Fit the O-ring in the O-ring groove of the battery cap.

**⚠ WARNING**

7. Use only an original Scubapro O-ring. This O-ring is Teflon coated and does not require additional lubrication.  
8. Do not lubricate the O-ring as the lubricant will chemically attack the battery cap.

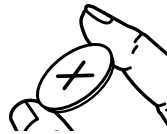

**⚠ WARNING**

9. Check the proper polarity of the battery. Aladin TEC 3G can be damaged if you do not insert the battery correctly. Insert the new battery, with “+” pointing outwards, into the battery compartment.

After battery replacement Aladin TEC 3G will perform an automatic test (8s) and gives a short beep when the test is done.

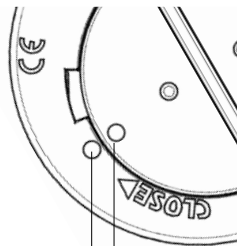

Alignment circles

**⚠ WARNING**

10. The battery cap can be installed with a  $\pm 120^\circ$  offset. The alignment circles are there to ensure proper positioning of the cap. If the rotation is stopped before alignment, watertightness may not be ensured. If the rotation is forced beyond the alignment, the cap may break. Damage to Aladin TEC 3G due to improper placement of the battery cap is not covered by warranty.

Push the battery cap firmly down and turn it clockwise until the two circles are aligned.

11. Check Aladin TEC 3G by switching on  $\circ \bullet$  ->15.

### 13.3 Warranty

The warranty only covers dive computers which have been bought from an authorised Scubapro UWATEC retailer. The warranty is given for a period of two years. Repairs or replacements during the warranty period do not increase the warranty period. In order to put forward a warranty claim: send the dive computer together with a dated receipt of the purchase to your authorised retailer or an authorised servicing point. Scubapro reserves the right to determine the merits of a warranty claim and to determine whether the computer will be repaired or replaced.

Excluded are faults or defects due to:

- excessive wear and tear;
- exterior influences, e.g. transport damage, damage due to bumping and hitting, influences of weather or other natural phenomena;
- servicing, repairs or the opening of the dive computer by anybody not authorised by the manufacturer;
- pressure tests which do not take place in water;
- diving accidents;
- improper placement of the battery cap.



Your dive instrument is manufactured with high-quality components that can be recycled and reused. Nevertheless these components, if not properly managed in accordance with the regulations on waste electrical and electronic equipment, are likely to cause harm to the environment and/or to human health.

Customers living in the European Union can contribute to protecting the environment and health by returning old products to an appropriate collection point in their neighborhood in accordance with EU Directive 2012/19/UE.

Collection points are in particular provided by some distributors of the products and local authorities. Products marked with the recycling symbol on the left must not be disposed of in normal household waste.



### 13.4 Index

Active backlight	19, 88	PC, transfer to PC (logbook)	10, 12
Alarm clock	19, 92	PDIS	54, 87
Altimeter5	38, 84	ppO <sub>2</sub>	22, 24, 30
AM/PM	93	Push buttons	6, 10
Apnea	44, 95	Reset to air	86
Ascent rate	24, 29	Residual Nitrogen bar graph	32
Audible attention signals	24, 89	Safety stop timer	35, 86
Backlight	19, 88	Set 1	84
Battery alarm	24	Set 2	91
Battery condition, Checking the...	17	Set 3	95
Battery lifetime	99	Setting the ppO <sub>2</sub> max	24, 59, 86
Battery replacement	99	SOS mode	20
Beep, Switch off the...	89	Sound, on /off	24, 94
CCR Settings	66, 85	Stopwatch	42
Changing the gas mixture	64	Surface interval	17, 77, 80
CNSO <sub>2</sub>	22, 22, 24, 31	Switching on/off the deco gas mixture	87
Date	17, 93	System	10
Deco data during deco phase	22, 32	Technical information	99
Decompression stop, Ignored...	24, 32	Time of day (display)	15, 92
Depth, current	27	Unit system	87
Depth alarm	28, 85	UTC	92
Desaturation time	16, 35	Warnings	24
Desaturation, reset the...	90, 99	Water contacts	11, 90
Display contrast	94	Water type	88
Dive	21		
Dive planner	76		
Dive time	27		
Dive time alarm	27, 86		
Dive, end of a dive	35		
LogTRAK	10, 12, 80		
E3, E6 error code	99		
Electronic ID	95		
Fly, no-fly time	16, 36		
Gas mixture, Setting...	24		
Gauge mode	41		
IrDA	94		
Light	19, 88		
Logbook	80		
Maintenance	99		
Max depth	21, 28		
Microbubbles	46		
MOD	22, 24, 25, 30, 59		
Mountain lakes, Diving in...	38		
Nitrogen loading bar graph	32		
Nitrox	22		
No-dive warning	36, 77		
No-stop time	21, 32, 46		
O <sub>2</sub> % mix, Set up...	24, 59		
O <sub>2</sub> fraction	21, 22, 24, 59		
O <sub>2</sub> partial pressure	22, 24, 30		
O <sub>2</sub> partial pressure, ppO <sub>2</sub> max	30, 59, 86		
O <sub>2</sub> toxicity	22, 24, 31		
Operating Aladin TEC 3G	6, 8, 10		